

## 244LD Intelligent Buoyancy Transmitter with Torque Tube and Displacer for Level, Interface and Density - All versions -



These intelligent transmitters are designed to perform measurements for liquid level, interface or density of liquids. The measurement is based on the Archimedes buoyancy principle. Easy remote configuration and supervision with PC or Universal Handterminal is possible. The devices also can be operated conventionally using local keys. The transmitters are approved for use in hazardous areas. The 244LD combines long years of experience by Foxboro with the latest digital technique.

### FEATURES

- Communication HART (also 4-20 mA), FoxCom, PROFIBUS PA or FOUNDATION Fieldbus
- Conventional operation with local keys
- Easy adaptation to the measuring point without calibration at the workshop
- Backdocumentation of measuring point
- Continuous self-diagnostics
- Configurable safety value
- Software lock for local keys and reconfiguration
- Approved for SIL applications
- Simulation of analog output for loop-check
- Local display in %, mA or physical units
- Signal noise suppression by Smart Smoothing
- Linear or customized characteristic
- Process temperature from  $-196\text{ }^{\circ}\text{C}$  to  $+400\text{ }^{\circ}\text{C}$
- Materials for use with aggressive media
- Micro sintermetal sensor technology
- Separate mounting of sensor and amplifier with remote amplifier mounting kit

## CONTENTS

CHP. CONTENTS	PAGE
1 DESIGN	3
2 METHOD OF OPERATION	3
2.1 Measuring principle	4
2.2 Block diagram with PROFIBUS	5
2.3 Block diagram with FOUNDATION Fieldbus	5
2.4 Block diagram with HART / FoxCom	6
2.5 Explanations to Block diagrams	6
3 IDENTIFICATION	10
Nameplates	
4 MOUNTING	12
4.1 High medium temperatures	12
4.2 Mounting on top of the vessel	12
4.3 Mounting on the side of the vessel	12
4.4 Kit for Remote Mounting	13
4.5 Mounting the wafer body	14
4.6 Displacer 204DE	16
5 ELECTRICAL CONNECTION	18
5.1 Signal wire connection	18
5.2 Ground	18
6 COMMISSIONING	19
7 DECOMMISSIONING	19
8 CALIBRATION OF TRANSMITTER	20
8.1 Hardware write protection	21
8.2 Calibration via local keys	21
Setting of Upper and Lower Range Value	22
8.3 Calibration via Display Keys	23
8.4 HART / FoxCom	24
8.5 PROFIBUS	30
8.6 FOUNDATION Fieldbus	36
9 DIMENSIONING OF DISPLACER	42
10 DIMENSIONS	44
11 SUPPLY OF TRANSMITTER	45
11.2 HART / FoxCom	45
11.3 PROFIBUS-PA	47
11.4 FOUNDATION Fieldbus	47

### Further documentation:

Master Instruction MI EMO0110 A-(en)  
HT991 Universal Hand terminal for HART Devices

Master Instruction MI EMO0120 A-(en)  
ABO991 Display and User Interface for HART devices  
WPP991 Write Protection Program

HHT Instruction Book 3372  
I/A Series Hand Held Terminal

PC10 Instruction Book 3466  
Intelligent Transmitter Configurator

## 1 DESIGN

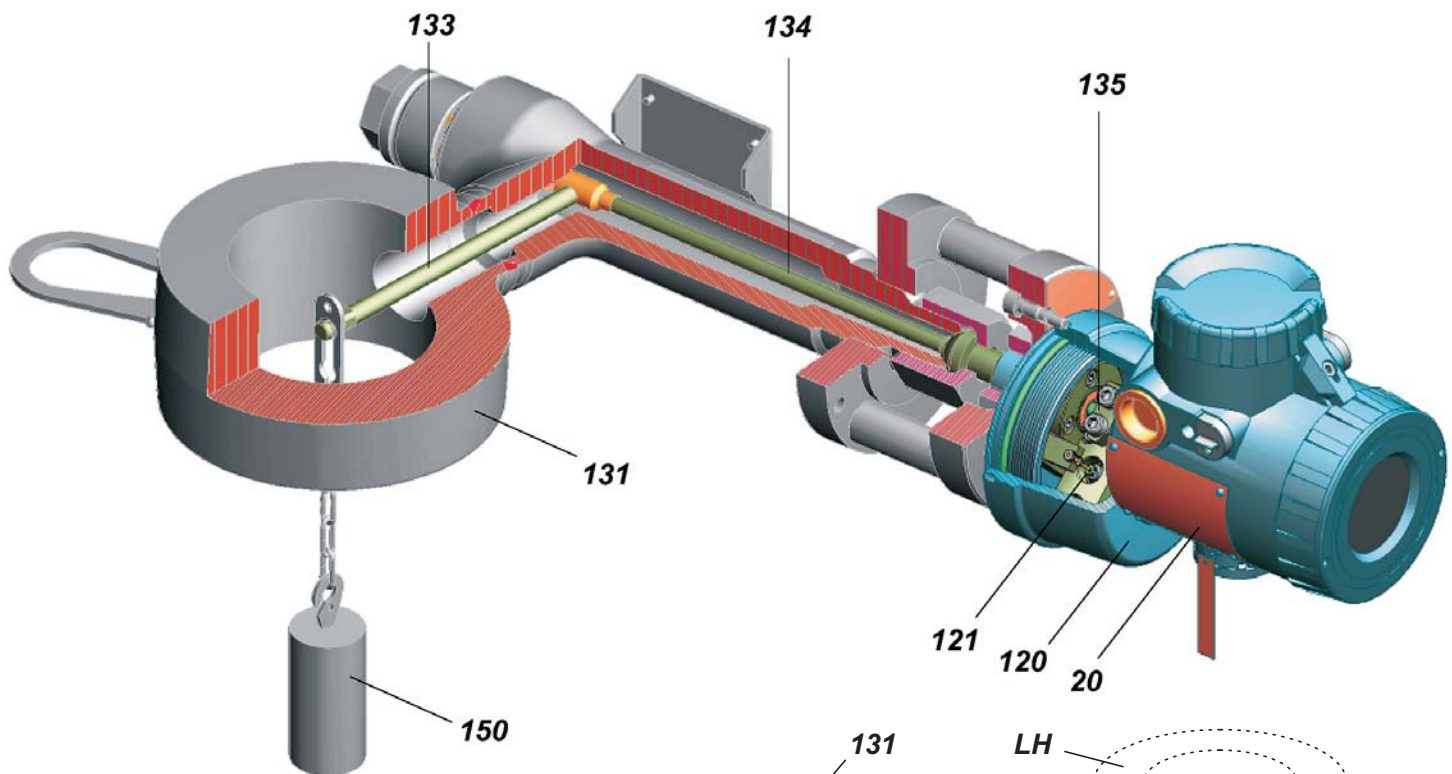

- 20** Amplifier
- 120** Sensor housing
- 121** Sensor
- 131** Wafer body with heat sink and torque tube
- 133** Transmission lever
- 134** Torque tube
- 135** Clamping lever
- 150** Displacer with suspension chain
- LH** Version for left-hand mounting

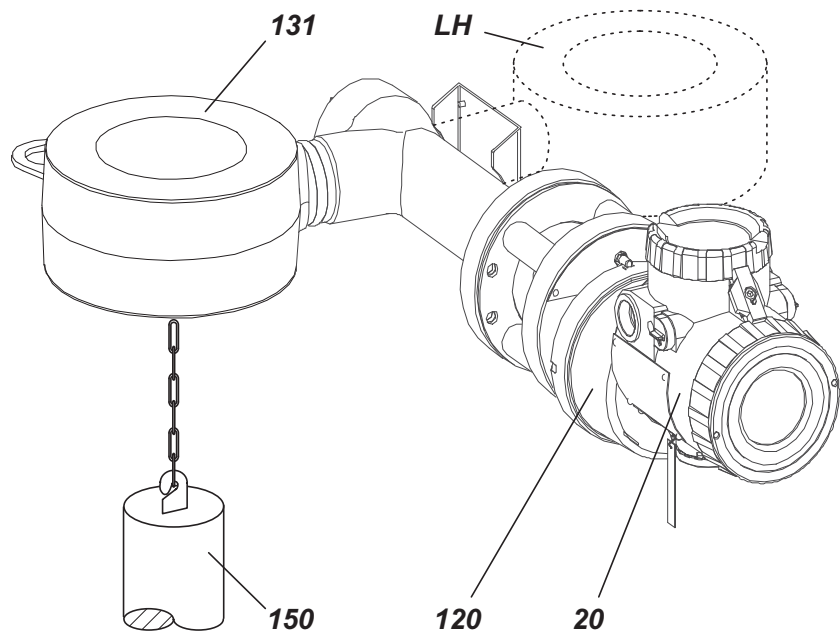

For left-sided mounting all inside parts are arranged in inversed manner.

## 2 METHOD OF OPERATION

The buoyancy force of the displacer **150** is transferred via transmission lever **133** and torque tube **134** to operating rod of the sensor, where it acts on free end of sensor element **121**.

Four thin film metal strain gauge elements are sputtered onto sensor element, which change their resistance in the ratio of the tensile or pressure tension. These four thin film metal strain gauge elements are connected as a Wheatstone full bridge supplied from amplifier.

The voltage at the diagonal bridge section which is proportional to the effective weight is fed to the electronic amplifier as an input signal.

This voltage is converted via the electronic amplifier into the 4 to 20 mA or digital two-wire output signal.

The amplifier is supplied by the signal current circuit in two-wire mode.

### 2.1 Measuring principle

(see VDI/VDE Guideline 3519, sheet 1)  
 Any body immersed into a liquid is subject to Archimedian buoyancy force which depends on the liquid density. This is exploited to determine liquid level, density and interface level by suspending a displacer with constant cylindric

shape into a liquid.  
 Changes in buoyancy forces are proportional to liquid level changes and are converted to a measuring signal.  
 The displacer is fully immersed for density and interface level detection.

The following applies in general to the buoyancy force acting on the displacer:

$$F_A = V_x \cdot \rho_1 \cdot g + (V - V_x) \cdot \rho_2 \cdot g$$

- $F_A$  Buoyancy force
- $V$  Volume of displacer
- $V_x$  Volume of medium displaced by measuring body with density  $\rho_1$
- $\rho_1$  Average density of heavier medium
- $\rho_2$  Average density of lighter medium
- $g$  Local acceleration due to gravity
- $F_G$  Displacer body weight force

The force acting on the transmitter is inversely proportional to liquid level changes.

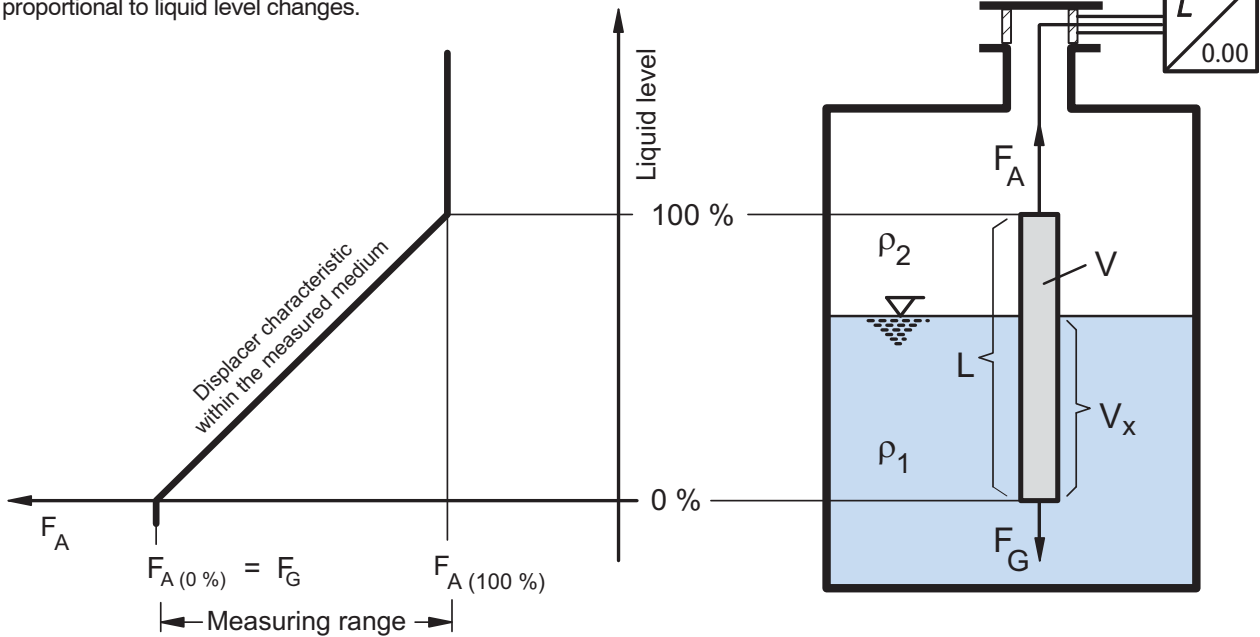

### 2.2 Block diagram with PROFIBUS

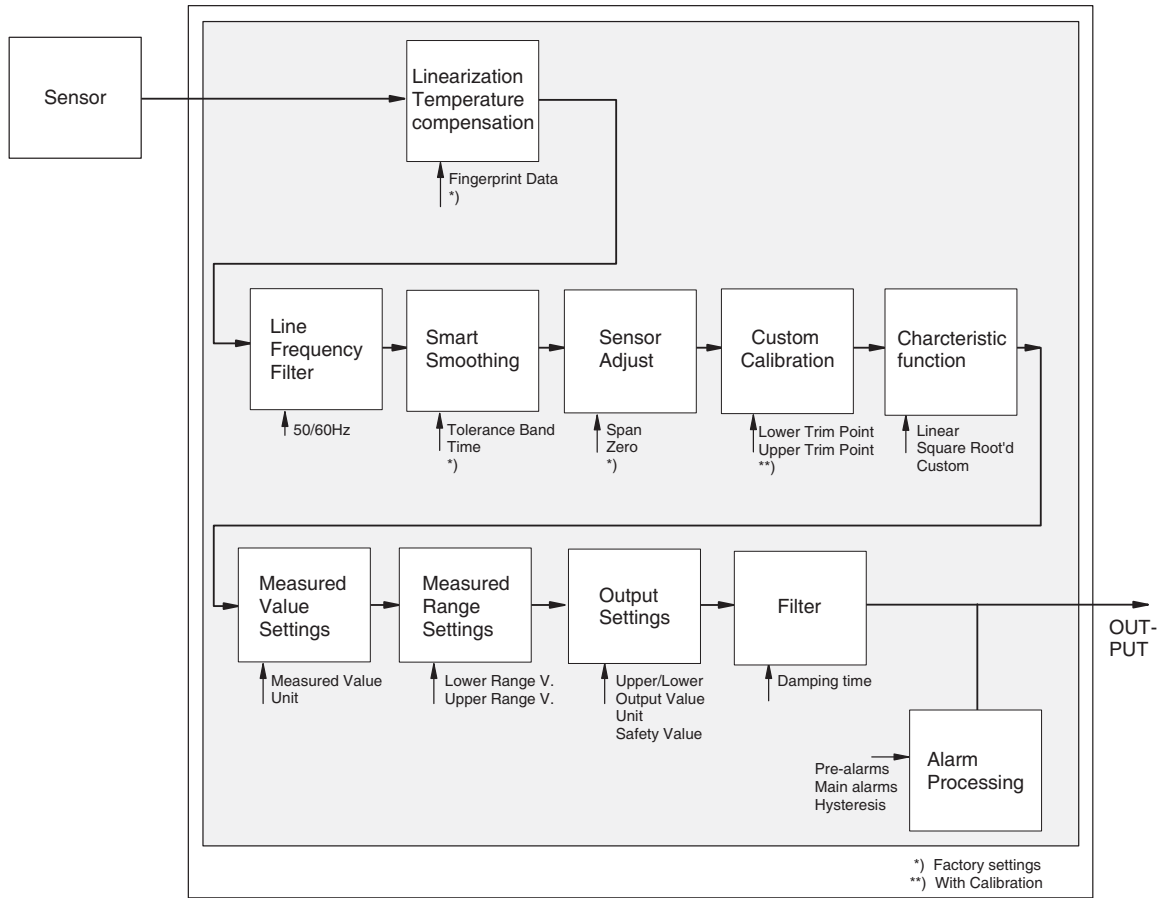

### 2.3 Block diagram with FOUNDATION Fieldbus

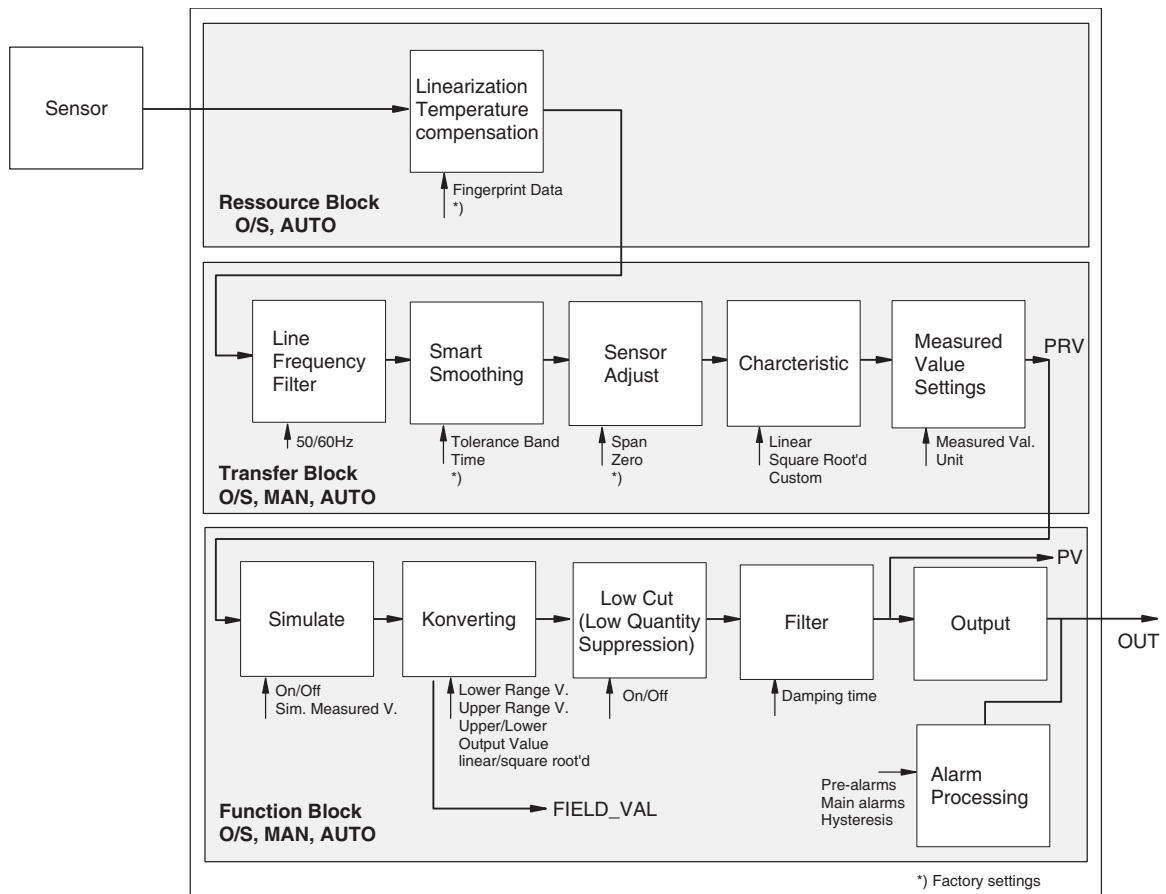

### 2.4 Block diagram with HART / FoxCom

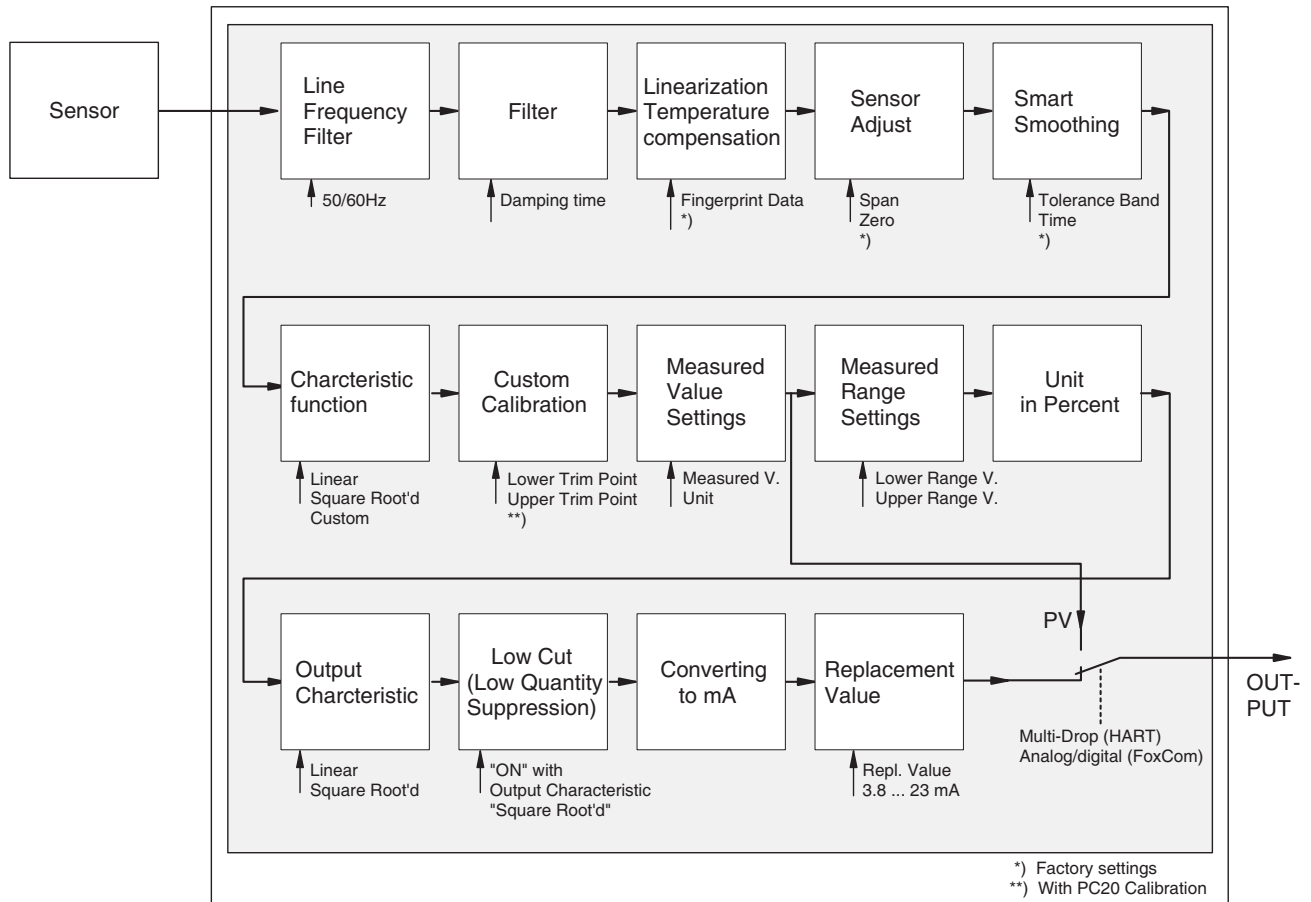

### 2.5 Explanations to Block diagrams

#### Sensor

The force sensor is a Wheatstone bridge of four metal strain gauge elements and a Ni100 resistor for temperature measurement. For calibration the sensor is loaded with weights, in order to determine the characteristic of the sensor. The Lower Range Value is determined by a small buoyancy force (high weight), Upper Range Value by a larger buoyancy force (lower weight).

#### Linearization and Temperature compensation of Sensor characteristic

The sensor signal is linearized and temperature-compensated by the included sensor temperature. Linearization takes place via the so-called fingerprint data, which are determined during the production for each sensor. In factory the fingerprint data are loaded into the amplifier.

#### Line Frequency Suppression Filter

There is the selection to filter the noise signal 50 Hz or 60 Hz.

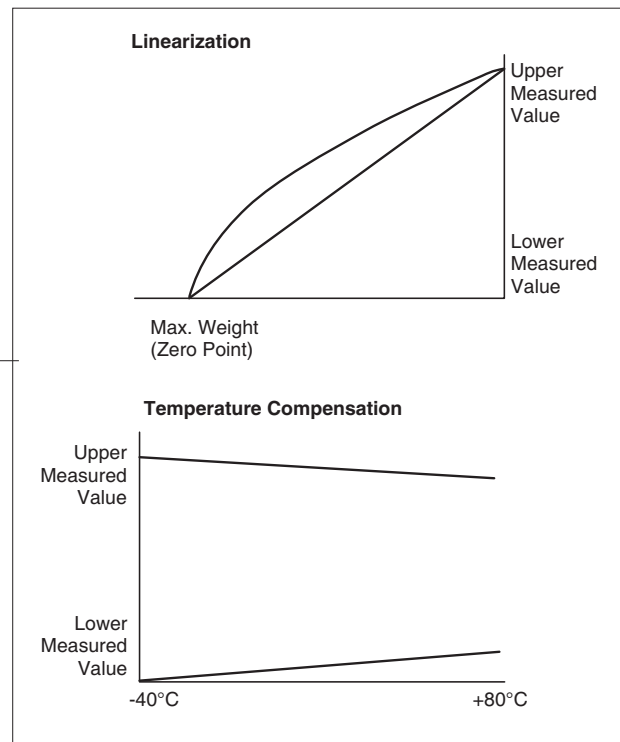

**Smart Smoothing**

In factory the Smart Smoothing Band is set to 0.15 % of sensor range. The Integration Time of the average value is set to 10 sec.

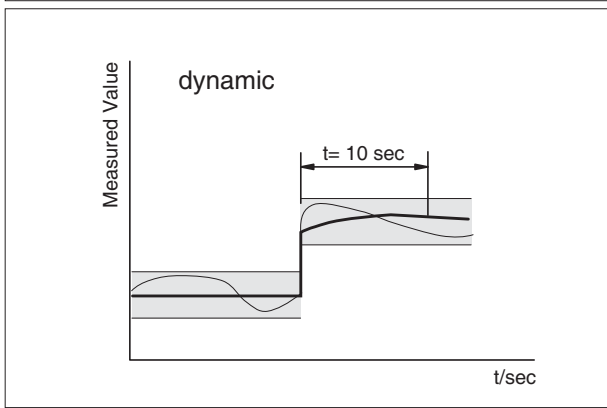
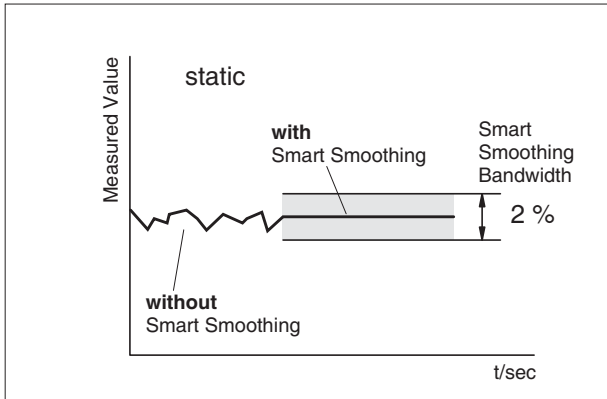

**Sensor Adjustment**

Zero and span of force sensor are adjusted in factory. It is possible to calibrate Zero (situation alignment) with the external key (see 8.2).

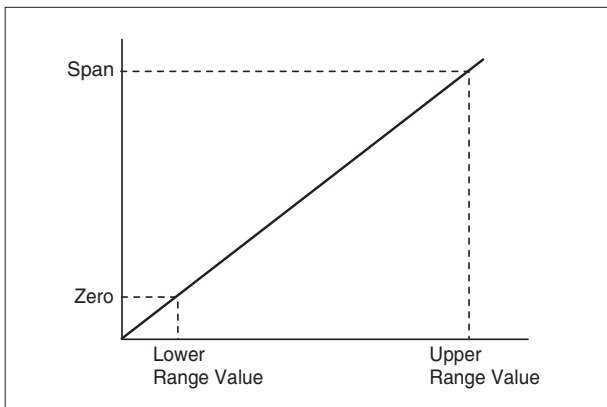

**Custom Calibration (not with Foundation Fieldbus)**

The user has the possibility with this function of calibrating the transformer according to his conceptions. By giving of a lower and upper measured value the transfer characteristic is again adjusted. This custom calibration can be reset to factory calibration.

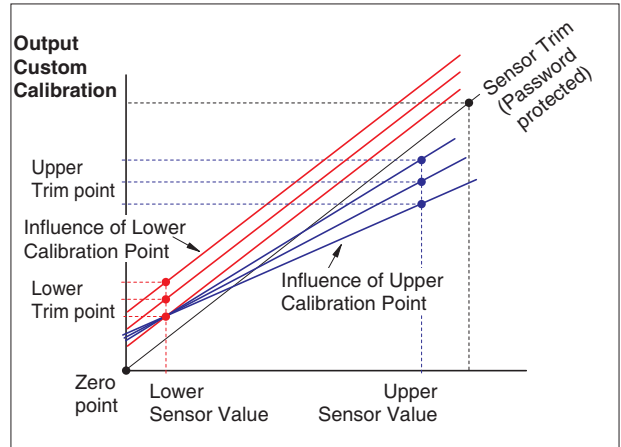

We only recommend a custom calibration with either lower plus upper calibration or an exclusive upper calibration.

**Transfer function / Characteristic**

The characteristics are available linear, root-extracted and customized. With "customized" there are 32 x/y- values available. Standard with Level is "linear".

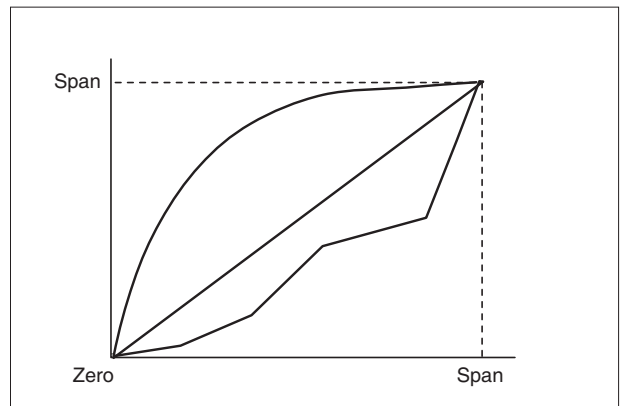

**Measured Value Setting**

The user can define measured value and unit.

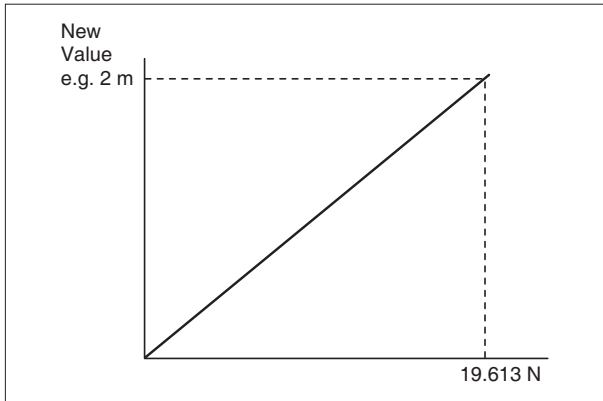

**Setting of Range (not with Foundation Fieldbus)**

The measuring range is the range between Lower Range Value and Upper Range Value. Lower Range Value is the weight of the displacer. Lower Range Value without elevation is 0. With elevation, the value of elevation has to be entered.

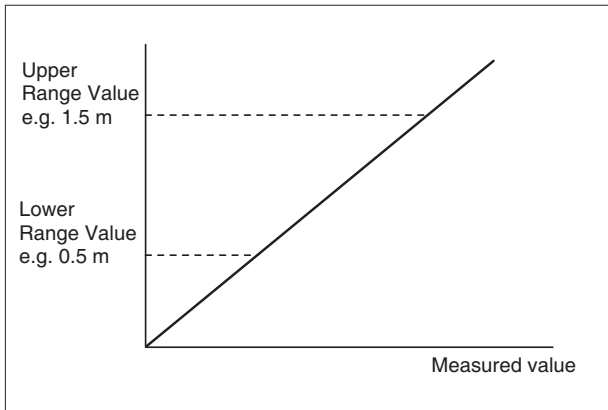

**Setting of Output value**

The output value is the measured value between Lower Range Value and Upper Range Value. Value and unit are freely selectable. The replacement value affects the output.

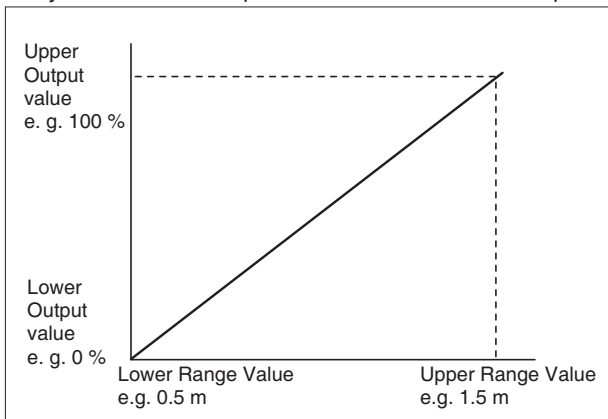

**Simulate (only FOUNDATION Fieldbus)**

After setting a flag it is possible to simulate the measured value with a FOUNDATION Fieldbus Configurator.

**Convert (only FOUNDATION Fieldbus)**

Lower/Upper Range Value and Lower/Upper Output Value are freely configurable for value and unit. The measuring range is the range between Lower Range Value and Upper Range Value. The output value is the measured value between Lower Range Value and Upper Range Value. The output value can be root-extracted.

One configures which values are set to the output value and the measured value (primary variable PV). There are following configuration possible:

- OUT/PV = measured value
- OUT/PV = Output
- OUT/PV = Output, root-extracted

The difference between OUT and PV is: With OUT is an Alarm processing but not with PV.

FIELD\_VAL is measured value in %.

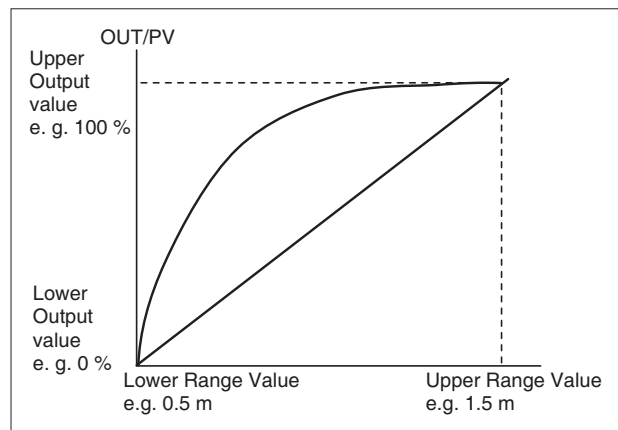
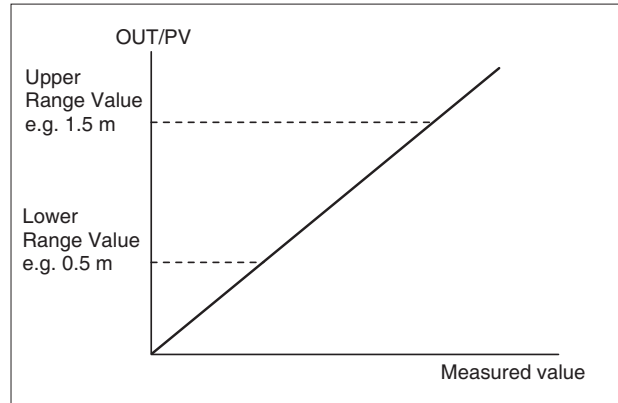



**Low Quantity Suppression (not with PROFIBUS)**

Setting On or Off for low quantity suppression with root-extracted output. With Level, low quantity suppression is always 0.

**Output characteristic (only with HART / FoxCom)**

The Output characteristic can be root- extracted.

**Replacement / Substitute Value (only HART / FoxCom)**

In case of error output holds last value or gives a configurable Replacement value.

If the error does not exist any longer, then "last value" and/ or replacement value is taken back (automatic or manuell).

**Multi-drop (only HART)****Analog/Digital Output (only FoxCom)**

With PC20 or a Hand Held Terminal it is possible to switch - HART-Amplifier between "analog" and "Multi-drop" - FoxCom-Amplifier between "analog" and "digital". With HART-mode "Multi-drop" the output has a digital signal, the measured value is modulated to a 4 mA DC signal. With FoxCom-mode "digital" the measured value is modulated to a 12 mA DC signal.

PC20 Software enables to simulate the measured value and to write output values directly to the output.

**Filter**

The output signal is damped; damping time ist setable from 0 to 32 sec (90%).

**Alarm processing (not with HART / FoxCom)**

The output signal is supervised by lower and upper pre- and main alarm limits and hysteresis. With exceeding of the alarm limits the status of output signal is set to alarm (PROFIBUS see TI EML 0610 P or Foundation Fieldbus TI EML0610 Q).

**Mode (here: PROFIBUS)**

With Configurator the block mode can be switched to AUTO, OUT OF SERVICE (O/S) and MAN.

In AUTO the block receives the measured values of the sensor and sends it after calculating by configuration to the output.

In O/S the block is out of service. This is the case if e.g. new parameters are sent by the Configurator.

In MAN the sensor is switched off. The output can be written directly by the Configurator.

**Mode (here: FOUNDATION Fieldbus)**

Each sub block (Ressource block, Transfer block, Function block) has own modes.

AUTO is normal operation. In AUTO the block receives a value from input, calculates the new value and stores it to the output.

In O/S the block is out of service. This is the case if e.g. new parameters are sent by the Configurator.

In MAN the block input is switched off. The output can be written directly by the Configurator.

**FURTHER INFORMATIONS****PROFIBUS**

Profibus-PA Profile for Process Control Device  
Communication with Profibus TI EML 06108 P

**FOUNDATION Fieldbus**

FOUNDATION Specification Transducer Block Application  
Process  
FOUNDATION Specification Function Block Application  
Process  
Communication with FF-Fieldbus TI EML 06108 Q

### 3 IDENTIFICATION

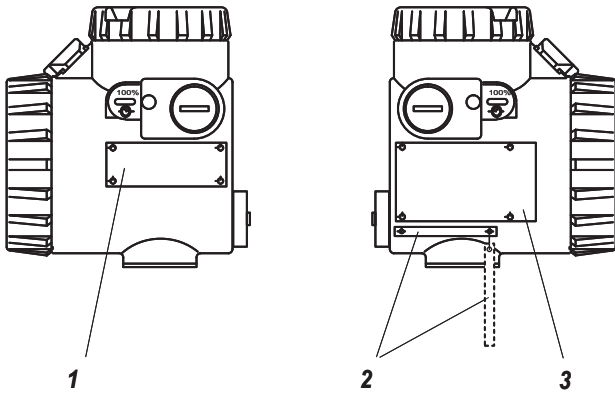

The transmitter is identified with several labels. The transmitter nameplate **1** shows the Model Code of transmitter, which clearly describes the device. The certificate data and the serial No. are shown on the amplifier nameplate **3**. The optional TAG No. label **2** with the Tag No. is located underneath.

ATEX-certified transmitters have an additional sensor label **8**.

#### Transmitter nameplate 1

(Example)

MESSUMFORMER / TRANSMITTER	
MODEL	[ ] [ ]
[ ]	
[ ]	
ECEP	[ ] REV.Nr. [ ] (4)

ECEP: ID No. for special version

Option Overfill protection acc. to WHG

#### Tag No. label 2

(Example)

Directly fixed or attached

LID 09/16
-----------

Optional label with devices acc. to NACE-Standard. With attached Tag No. label, on the rear side of Tag No. label.

#### Amplifier nameplate 3

(Examples)

VERSTÄRKER / AMPLIFIER		CE
EBE	[ ] SER.No. [ ]	
KOMMUNIKATION		
<input type="checkbox"/> 4 ... 20 mA	<input type="checkbox"/> FOXCOM IT1	<input type="checkbox"/> PROFIBUS acc. FISCO
<input type="checkbox"/> HART	<input type="checkbox"/> FOXCOM IT2	<input type="checkbox"/> FF FIELDBUS H1
HILFSENERGIE POWER SUPPLY	[ ]	AUSGANG / OUTPUT [ ]
	Made in Germany by FOXBORO ECKARDT GmbH D - 70376 STUTTGART	

Without explosion protection

VERSTÄRKER / AMPLIFIER		CE
EBE	[ ] SER.No. [ ]	0102
KOMMUNIKATION		
<input type="checkbox"/> 4 ... 20 mA	<input type="checkbox"/> FOXCOM IT1	<input type="checkbox"/> PROFIBUS acc. FISCO
<input type="checkbox"/> HART	<input type="checkbox"/> FOXCOM IT2	<input type="checkbox"/> FF FIELDBUS H1
PTB Nr. [ ]	ATEX [ ]	TYPE [ ]
[ ]		
<input type="checkbox"/> Pi	<input type="checkbox"/> Ui	<input type="checkbox"/> li
<input type="checkbox"/> Ci	<input type="checkbox"/> Li	<input type="checkbox"/> Tamb
siehe Betriebsanleitung see Instruction Manual		
		Made in Germany by FOXBORO ECKARDT GmbH D - 70376 STUTTGART

With explosion protection acc. to ATEX

ELECTRICAL TRANSMITTER	
SER. No.	[ ]
	EXPLOSIONPROOF FOR CLASS I, DIV. 1, GROUPS B, C, D. DUST-IGNITIONPROOF FOR CLASS II, III, DIV. 1, GROUPS E, F, G; NEMA 4X. SEAL ALL CONDUITS WITHIN 18 INCHES. UNUSED CONDUIT IS TO BE SEALED WITH THE PLUG PROVIDED. DO NOT REMOVE COVER WHILE CIRCUITS ARE LIVE.
OUTPUT [ ] mA	TERMINAL VOLTAGE DC 12...42 V
	TEMP. 185° F (85°C)
	CE

With explosion protection, Type of protection  
"Explosionproof" FM

All FM and CSA approved versions have an additional wiring label on the amplifier housing.

(Further Amplifier nameplates, not shown)

### Adjustment data label 7

Matching the displacer:

Take care of correct matching of transmitter and displacer while mounting. Each transmitter is calibrated to the respective displacer according to the ordering data in the factory. Each displacer is marked with the TAG No. or, if not known, with the last three digits of serial number of the respective transmitter.

If this identification is non-legible, displacer data can be determined by measuring and comparison with the data on Adjustment data label 7.

EINGESTELLT AUF / ADJUSTED TO VERDRÄNGER / DISPLACER	L ⇒ mm
	V ⇒ cm <sup>3</sup>
	FG ⇒ N
	P max ⇒ bar
	ρ2 ⇒ kg/m <sup>3</sup>
	ρ1 ⇒ kg/m <sup>3</sup>
	F <sub>0</sub> ⇒ N
	F <sub>100</sub> ⇒ N

**Length L:** Length of displacer  
(= measured length) in mm

**Volume V:**  $0.25 \cdot L \cdot d^2 \cdot \pi$  (L and d in cm !)  
L = Length of displacer = measured length  
d = Diameter of displacer

**Weight force FG:** To be determined by weighing [kg]<sup>\*)</sup>

### Sensor label 8

Additional on ex-proof devices.

LEVEL TRANSMITTER	
AUFNEHMER FÜR FÜLLSTAND	
PTB Nr. [ ] ATEX [ ]	TYP [ ]
Ser. Nr. [ ]	
Werte siehe Betriebsanleitung Data see instruction manual	
Made in Germany by FOXBORO ECKARDT GmbH D - 70376 STUTTGART	
	

### Torque tube material label 6

TORSIONSROHR - WERKSTOFF	
TUBE DE TORSION - MATERIAL	
WNr. 2.4610 (HC)	[ ]
WNr. 2.4816 (In)	[ ]
WNr. 1.4404 (VA)	[ ]
WNr.	[ ]

### Boiler label 9

Boiler label with nominal pressure, material, permissible pressure and temperature load, serial no., etc

GEHÄUSE VON ARMATUREN	
BODY OF TRANSMITTER	
BAUJAHR / YEAR [ ]	
INHALT / VOLUME LI [ ]	
SER. Nr. [ ]	0036
WERKSTOFF / MATERIAL [ ]	
PN [ ]	
PRÜFDRUCK / TEST PRESSURE [ ] bar	
ZUL. UEBERDRUECKE IN ABHAENGIKKEIT D. TEMPERATUR	
PERMISSIBLE PRESSURE-TEMPERATURE RATINGS	
SURPRESSION ADMISSIBLE	
*C	[ ] [ ] [ ] [ ] [ ] [ ] [ ] [ ] [ ] [ ]
bar	[ ] [ ] [ ] [ ] [ ] [ ] [ ] [ ] [ ] [ ]
< -10 °C BEI R. TEMP. SCHRÄUBEN AUS A2/A4 VERWENDEN	
USE SCREWS MADE FROM A2/A4 WHEN OPERATING	
TEMPERATURE IS < -10°C	
Made in Germany by FOXBORO - ECKARDT GmbH D-70376 STUTTGART	
	

With option Wasserstand 100 the certification number label is mounted above the Boiler label.

Location of labels:

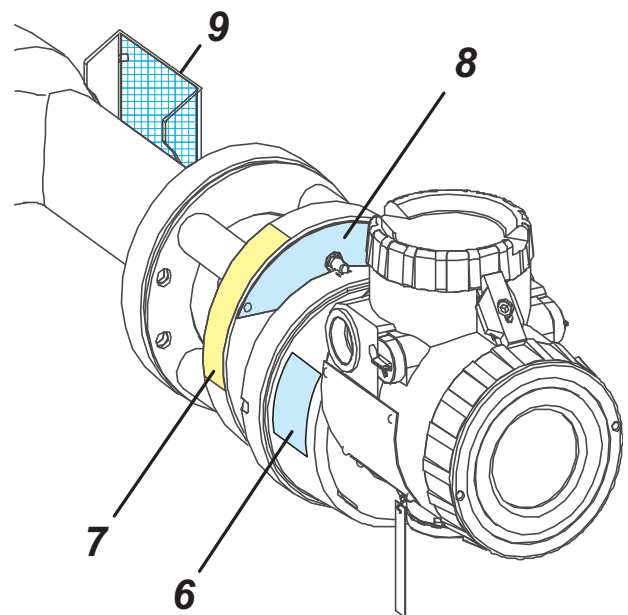

\*) Attention! 1 kg generates a force of 9.807 N

## 4 MOUNTING

The transmitter is directly built onto the vessel or alternatively on a side-mounted displacer chamber (e.g. 104DC).

During installation, the permissible static pressure and the ambient temperature range must be observed. (see chap. 3, Boiler label).

### 4.1 High medium temperatures

The permissible ambient temperature must be limited for some applications with high medium temperatures: If condensing media with a high heat capacity are used (e. g. saturated steam about 300 °C), or if the wafer body has a heating jacket and is heated with thermal oils (approx. 300 °C), the ambient temperature directly at the sensor housing and at the amplifier must not exceed 50 °C.

If the maximum permissible temperatures (sensor housing 120 °C, amplifier 85 °C, LCD indicator 80 °C) are exceeded, all parts which radiate heat must be insulated (wafer body, displacer chamber, vessel), to ensure that no heat radiation reaches the housing of the sensor or the amplifier. Direct sunlight on the sensor and the amplifier housing should be avoided.

Heating jackets of wafer bodys are designed for PN 25 / Class 300.

### 4.2 Mounting on top of the vessel

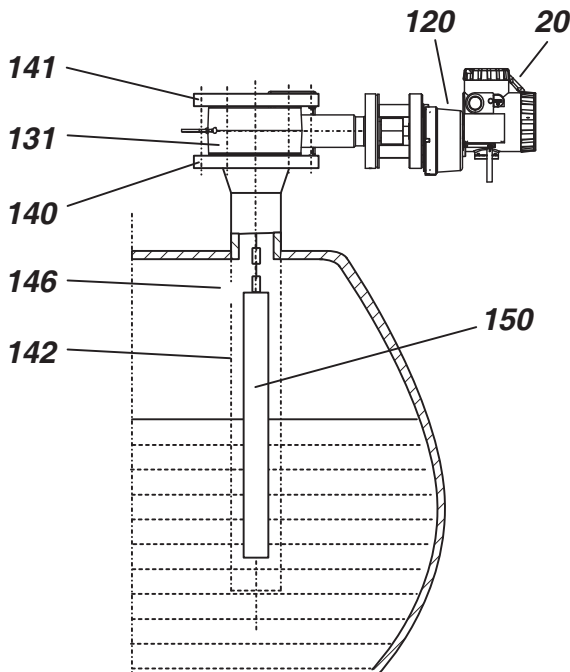

- |                       |                          |
|-----------------------|--------------------------|
| 20 Amplifier          | 141 Blind flange         |
| 120 Sensor housing    | 142 Protection cage/tube |
| 131 Wafer body        | 146 Venting hole         |
| 140 Connecting flange | 150 Displacer 104DE      |

If the vessel contains a turbulent liquid a protection cage / tube should be used. It has a venting hole **146** above the maximum liquid level. Between the protection cage / tube **142** and the displacer **150** must be a gap of 5 ... 10 mm.

### 4.3 Mounting on the side of the vessel

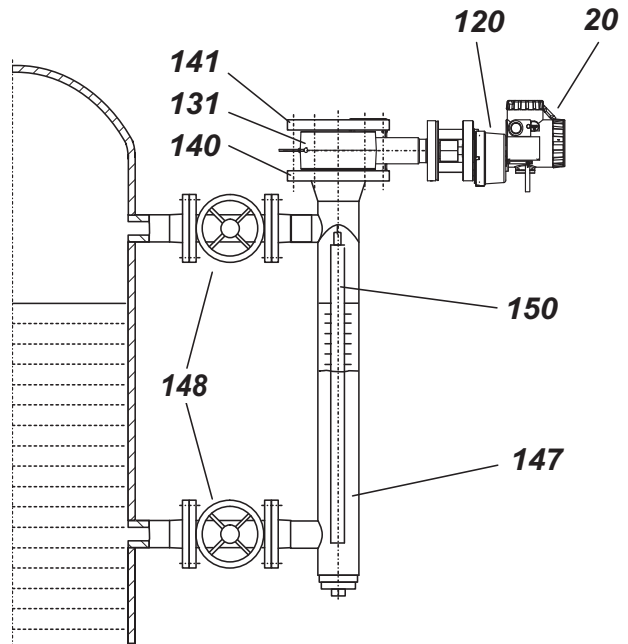

- 147** Displacer chamber 104DC  
**148** Shut-off device

When used in Zone 0, fittings resistant to flame penetration must be used.

If the chamber has not already been mounted by the customer, it must be mounted on the vessel with suitable bolts and seals (not included in the scope of delivery). Be sure that the displacer chamber is exactly vertical.

Between the protection cage or tube and the displacer must be a gap of 5 ... 10 mm.

**NOTE:**

For explosion-proof devices or devices with certification as overfill protection as per WHG, the remarks in the product specifications PSS EML0710 A and in the certificates or approvals must be observed.

#### 4.4 Remote Amplifier Mounting Kit

Sensor and amplifier can be spatially separated and are connected by means of feeder cable (3 m or 10 m).

This is used

- if the local indicator is to be attached some Meters away from the measuring point, e.g. to make easier reading
- to protect the amplifier against extreme operating conditions.

On delivery sensor, feeder line and amplifier are assembled ready-to-install.

For wall mounting, or mounting at horizontal or vertical pipe  $\varnothing 40..64$  mm the MS41-... Mounting Kit is recommended.

Remote Amplifier Mounting is not possible with electrical classification "explosionproof".

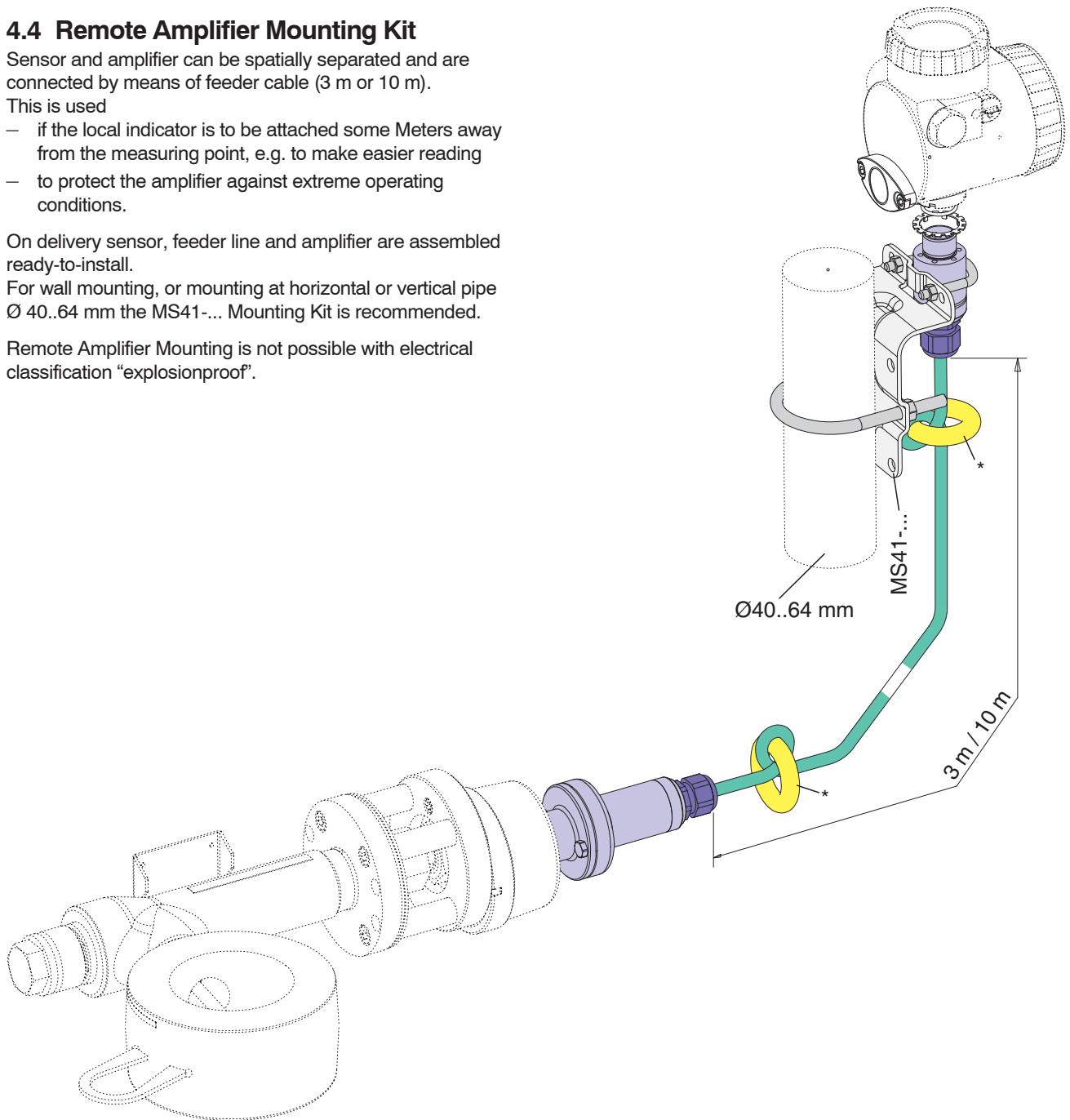

\*) Ferrite rings

## 4.5 Mounting the wafer body

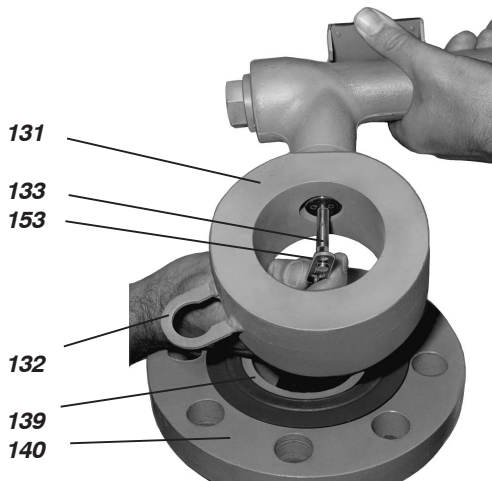

Place the seal **139** <sup>1)</sup> on the connecting flange **140** . Insert displacer in displacer chamber or vessel. Hold wafer body **153** above connecting flange. Engage eyelet **132** of displacer chain in notch in transmission lever **133** and fit wafer body onto connecting flange.

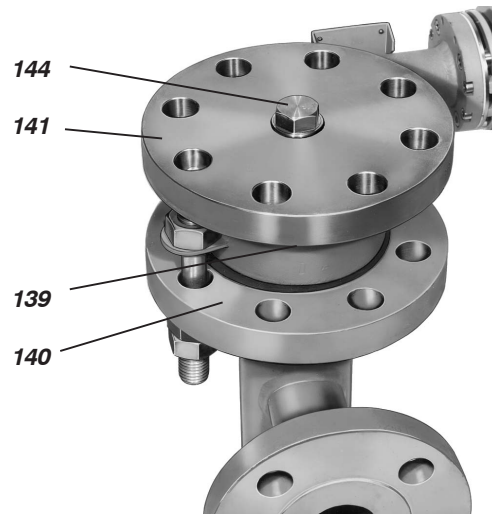

Place seal **139** <sup>1)</sup> on wafer body. Place blind flange **141** on wafer body so that holes in blind flange and connecting flange **140** are aligned. Blind flange can be equipped with vent plug **144** .

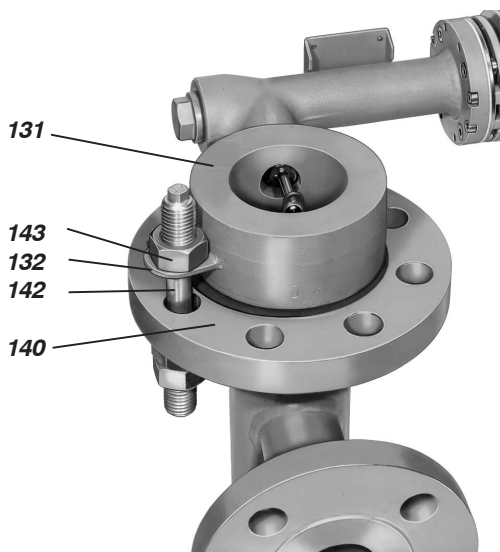

In order to make mounting easier, mounting bracket **132** is secured with a stud **142** to connecting flange **140** . It is advisable to preassemble a stud by screwing a nut **143** onto thread.

Insert this stud through the top of mounting bracket and connecting flange. Screw sufficient number of nuts onto thread and reduced shaft from underneath for the wafer body **131** to be firmly in position.

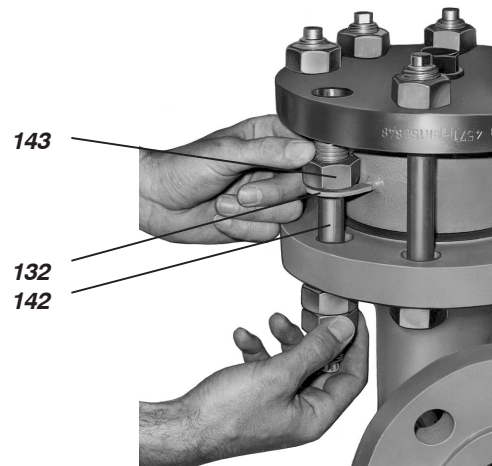

Leave stud **142** in mounting bracket **132** and insert remaining seven studs. Screw on nuts and tighten gently. Unscrew nut **143** and pull stud downwards.

1) When using an electrically non-conducting soft gasketing, the wafer body must be grounded, see chap. 5.2 .

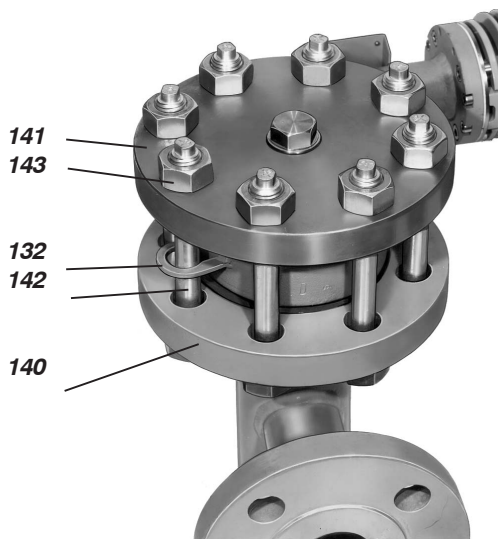

Push stud **142** through connecting flange **140**, mounting bracket **132** and blind flange **141**.

Screw on nut **143**. Tighten nuts of all eight studs cross-wise in several steps to recommended tightening torque.

<b>Recommended tightening torque</b> (Prestressed to 70% of minimum yield point at 20 °C)						
Studs	M16	M20	M24	M27	M30	M36
Tightening torque [Nm]	95	185	310	450	630	1080

### Note:

Studs and nuts material depends on material of wafer body and temperature of process medium. These parts are delivered by FOXBORO in accordance with the table below unless otherwise specified in the order:

Wafer body material	Temperature of measuring medium	Studs *)	Nuts *)
Steel C 22.8	-10 ...+350°C	GA	G
Steel 15 Mo 3	-10 ...+500°C		
316L (1.4404)	-10 ...+400°C	A2-70	
316L (1.4404)	-60 ...+400°C		

\*) Identification  
 Studs: GA; A2-70 ≤ M30  
           A2-50 > M30  
 Nuts: G; A2-70 ≤ M20  
        A2-50 > M20

## 4.6 Displacer 204DE

Ensure correct matching of transmitter and displacer while mounting. Each transmitter is calibrated to the respective displacer according to ordering data in the factory. Each displacer is marked with the TAG No. or, if not known, with the last three digits of the serial number of the respective transmitter. The corresponding displacer data (length, volume and weight) are specified on the adjustment data labels mounted on the cover of the sensor housing. See also chap. 3 "Adjustment data label".

### Replacing displacer

Enter the changed data of displacer on the adjustment label **7** (see chapter 3).

### Pressure Rating

The displacer must be designed for the pressure rating of the vessel - however, at least to the operating pressure - and ordered accordingly. Here the maximum possible temperature must be taken into consideration. Displacers made of PTFE are made from solid material, and are, therefore, suitable for all pressures

### Jointed displacer elements

Displacers of length over 3 meters (1 m for PTFE) are jointed (multi-section) displacer elements. The displacer elements are screwed together and secured with the wire clip **151** to avoid bending or damage during insertion into the vessel. The elements of displacers with  $\varnothing < 13$  mm are not screwed together; they are secured with hook and eyelet **152**. Additional securing is not necessary <sup>1)</sup>.

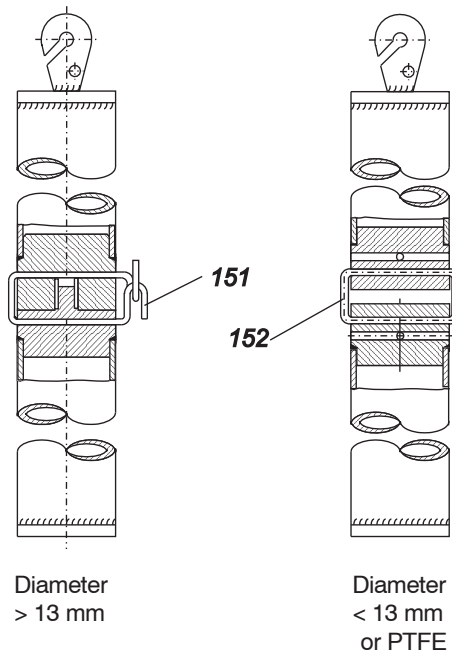

1) When used in Zone 0, the eyelets must also be welded.



### Damping element

In operating conditions with strong external vibrations - e.g. nearby compressor stations - the damping element (Option -D) should be used.

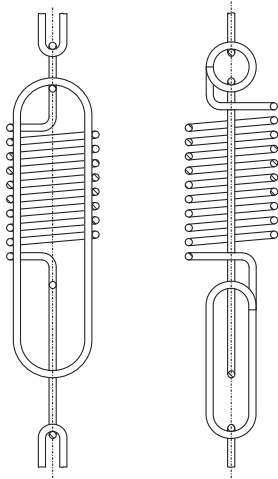

It is hooked onto the suspension chain of the displacer in place of 7 chain links (105 mm). This spring is specially matched to the resonance frequency of the displacer and is made of stainless steel 1.4310 (operating temperature up to 250 °C) or Hastelloy C (operating temperature up to 350 °C).

**Use in Zone 0 or as overfill protection according to WHG <sup>1)</sup>**

### Mechanics

When used in Zone 0, displacers must be secured against oscillating when

- displacer made of metal, explosion group IIC
- displacer made of metal, explosion group IIB/A, length > 3 m
- displacer made of PTFE+25% carbon, IIC/B/A, length > 3 m

The displacer is to be attached in such a way that it is not in the main filling jet stream.

When used as overfill protection according to WHG, the displacer must always be installed with guidance.

Guidance devices over 3 m long must also be secured against bending.

### Potential equalization

When used in Zone 0, only displacers of metal or PTFE +25 % carbon may be used.

A potential equalization line must be mounted as an electrical bypass of the displacer suspension(s) if the residual displacer weight is < 10 N, or if more than 6 contact points are present.

To avoid the danger of electrostatic ignition, a connection to the transmitter with good conductivity must be ensured.

The volume resistance between the lower end of the displacer and ground may not exceed 1 MΩ.

### Note for displacers with diameters less than 30 mm

Displacers with diameters < 30 mm can also be suspended when the wafer body has already been mounted.

As an aid to installation, a wire can be pulled through the hole in the eyelet **153**. The displacer is lowered through the wafer body with this wire, past the transmission lever and into the displacer chamber or vessel. The eyelet must then be hooked onto the notch **133** in the transmission lever.

Finally remove the wire.

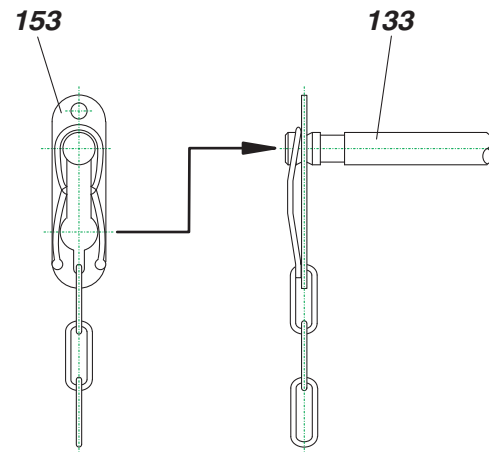

Hooking the eyelet onto the notch in the transmission lever

1) Please see corresponding certificates for further details

## 5 ELECTRICAL CONNECTION

### 5.1 Signal wire connection

Guide  **cable**  through cable gland  **38**  ; observe especially the shielding.

Check before mounting cable glands if threads are matching, otherwise housing can be damaged. Cable gland  **38**  and cover screw  **39**  are interchangeable.

Connect  **analog input signal**  (versions HART / FoxCom) to terminals  **45 (+)**  and  **46 (-)** .

Connect  **bus signal**  (versions PROFIBUS / FOUNDATION F.) to terminals  **45**  and  **46**  ; no polarity has to be observed.

The screw terminals are suitable for wire cross sections of 0.3 to 2.5 mm<sup>2</sup>.

The  **shield**  of the bus connection is

- with conducting cable glands (recommended) directly connected with the housing
- with non-conducting cable glands to be laid onto the inner screw terminal  **47**  .

**Note:**  When connecting the shielded bus connections, the shielding has to be connected on both sides! (on the transmitter as well as on the panel side).

For selection of the cable see also the recommendation for cable types acc. to IEC 1158-2.

Transmitters supplied without cable gland, the cable gland used has to conform to possible Ex requirements. This is the user's responsibility.

#### Actions:

- Tighten cover lock  **24**  (if provided) and unscrew cover  **22** .
- Guide cable through cable gland and connect to terminals  **45** ,  **46**  and  **47** .
- If necessary connect external ground terminal  **48** .
- Proper installation of cable gland has to be observed.
- Screw cover  **22**  and install cover lock  **24**  (if provided).

#### Note:

For explosion-proof devices follow reference for cable gland and cover screw in document "Safety Instructions 140 Series"

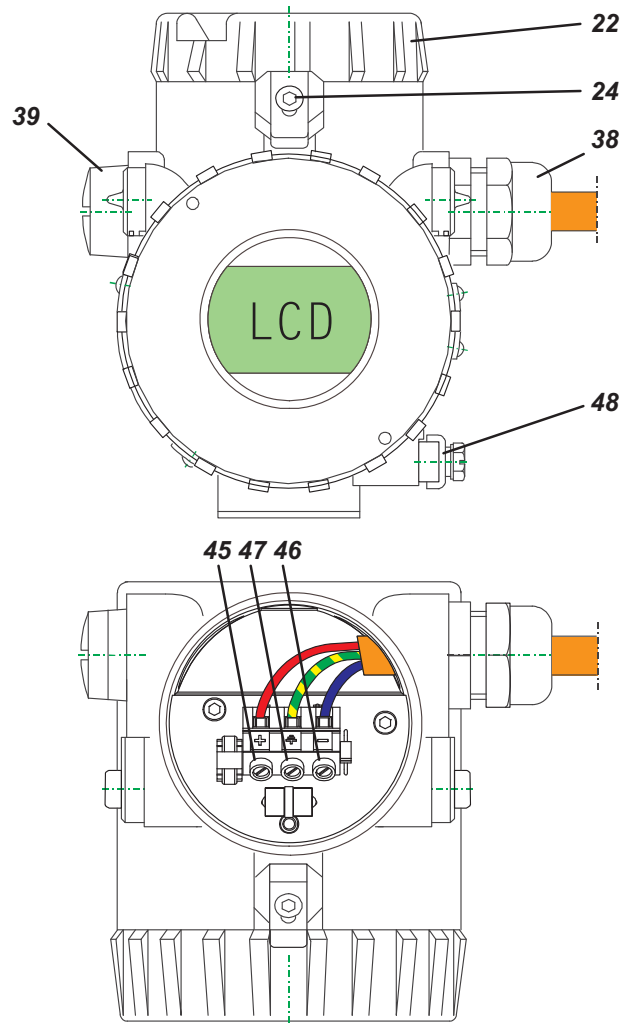

- |             |                                     |  |
|-------------|-------------------------------------|--|
| <b> 22 </b> | Connecting compartment cover        |  |
| <b> 24 </b> | Cover lock                          |  |
| <b> 38 </b> | Cable gland                         | (permitted cable diameter 6 to 12 mm)              |
| <b> 39 </b> | Cover screw                         |  |
| <b> 45 </b> | Connection terminal "+"             | wire cross   |
| <b> 46 </b> | Connection terminal "-"             | section  |
| <b> 47 </b> | Ground terminal                     | max. 2.5 mm <sup>2</sup>                           |
|             |                                     | Test sockets (Ø 2 mm) integrated in terminal block |
| <b> 48 </b> | External ground terminal            |  |
| <b> 50 </b> | Overvoltage protection (if present) |  |

### 5.2 Ground

If connection to ground is necessary (e.g. potential equalization, protection of electromagnetic influence), ground terminal  **47**  or external ground terminal  **48**  must be connected.

When using an electrically non-conducting gasketing, the wafer body must be grounded by wire  **E**  with the connection flange.

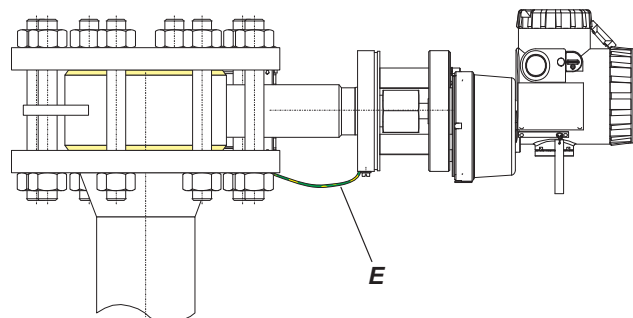

## 6 COMMISSIONING

In any case, installation and safety regulations have to be checked prior to commissioning. See document EX EML 0010 A: “**Safety Operating Instructions**”

After correct installation and connection to power supply unit, the transmitter is ready for operation:

$U > 12 \text{ V dc}$  (HART/ FoxCom)

$U > 9 \text{ V dc}$  (PROFIBUS / FOUNDATION Fieldbus)

If necessary the configuration of lower range value, upper range value and damping has to be checked.

With the **analog** versions HART/FoxCom an ampmeter can be attached into the output current loop for check.

### Checking the settings

#### Checking the lower range value for level measurement

For level measurements, the weight  $F_G$  of the displacer is equal to the weight force  $F_0$  for the lower range value (LRV). An exception is the measuring range with elevation. The lower range value (LRV) can be checked with a free-hanging displacer and a completely empty vessel.

#### Checking the lower range value for measuring range with elevation

The lower range value (LRV)  $F_0$  can only be checked by specifying the vessel level corresponding to  $F_0$  or by specifying the weight for  $F_0$  (workshop task).

#### Checking the lower range value for interface and density

The lower range value (LRV)  $F_0$  can be checked with the following methods:

- Displacer is completely immersed in the liquid with the lower density
- by specifying the weight force for  $F_0$  with weights (in the workshop)

#### Upper range value

The upper range value (URV)  $F_{100}$  can be checked with the following methods:

- by producing the corresponding level, interface or density, provided the specified operating densities are correct.
- by specifying the weight force for  $F_{100}$  with weights (in the workshop).

#### Damping

Damping of 8 sec is set at factory. If necessary, this value can be checked on devices with an LCD indicator and changed locally.

#### Correction of lower range value, upper range value, damping

See chapter 8, “Setting of Transmitter”.

## 7 DECOMMISSIONING

Prior to decommissioning take precautions to avoid disturbances:

- Observe Ex. protection.
- Switch off power supply.
- Caution with hazardous process media!  
With toxic or harmful process media, observe relevant safety regulations.

Before dismantling the transmitter, the procedure below should be followed:

- Depressurize vessel or displacer chamber.
- Drain off measuring medium in displacer chamber.
- Protect the environment; do not allow measuring substance to escape. Catch and dispose them properly.

The procedure for dismantling the transmitter is the reverse of that described for mounting.

#### Note:

Proceed with caution during all installation work.  
**Do not damage the diaphragm!**  
**Do not drop the suspended displacer!**  
**Avoid jointing!**

## 8 SETTING OF TRANSMITTER

Zero, lower range value, upper range value and damping of the transmitter are set by manufacturer as specified in the order:

- Dimensions of displacer: Length, density, weight
- Setting Lower Range Value by weight  $F_0$  :  
without Zero elevation = 0;  
with Zero elevation = Value of elevation
- Upper Range Value corresponding to buoyancy force of displacer (see Chap.9)
- Output Range and unit

Therefore, calibration at start-up is not necessary.

In case the order does not include this data, the transmitter is supplied as follows:

displacer weight	=	1.500 kg
buoyancy force	=	5.884 N (0.600 kg)
indication	=	0 ...100 %
damping	=	8 sec (90 % time)

Operating data and displacer data are stored in the transmitter according to the order.

Configuration becomes necessary if this data deviates from the values stored.

The transmitter is designed for a displacer weight force of max. 4 kg<sup>1)</sup> and a buoyancy force of 2 to 20 N. The lower range value  $F_0$  must be within the range 4 kg to 2 kg (special version 0.5 kg).

### Setting via operating push buttons

Setting can be done by means of the push buttons at the transmitter if

- the amplifier housing has external push buttons **X**, see Chap. 8.2 "Setting via local keys", or
- the display has push buttons **D**, see Chap. 8.3 "Setting via Display keys".

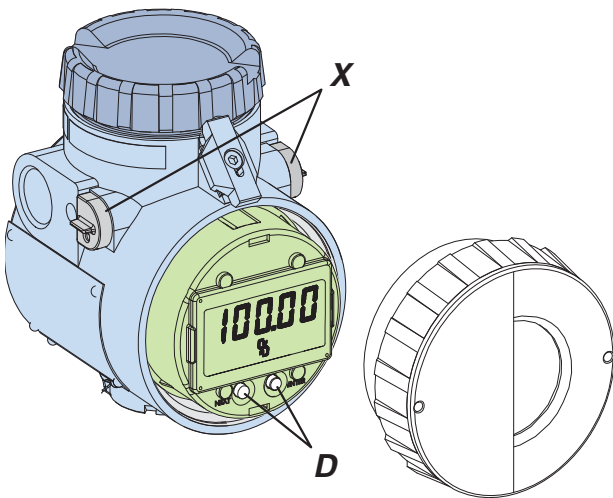

### Setting via HART Protocol

- Setting with PC; Display and User Interface PC20
- Setting with Handterminal
- Basic calibration with PC20 Calibration (necessary if sensor or amplifier are changed)

### Setting via FOXC0M Protocol

- Setting with PC; software PC10 / PC20
- Setting with FoxCom Hand terminal
- I/A Series System IFDC software
- Basic calibration with PC Calibration (necessary if sensor or amplifier are changed)

### Setting via PROFIBUS Protocol

- Setting with PC; Display and User Interface PC20

### Setting via FOUNDATION Fieldbus Protocol

- Manufacturer's Sensor calibration (Fingerprint data, zero, span)
- Customer's settings with standard configurators, as National Instruments Configurator, Honeywell System (DCS), Siemens Delta V (Emerson), ABB

1) Attention! 1kg generates a force of 9.807 N

## 8.1 Hardware write protection

The write protection prevents the changing of the configuration of the transmitter. To enable writing on the transmitter, the jumper **J** has to be plugged as shown in the figure below. (Amplifier electronics, behind LCD indicator)

**Note:** Additional Software Write Protection can be reset / set via PC20 Software.

### HART / FOXCOM:

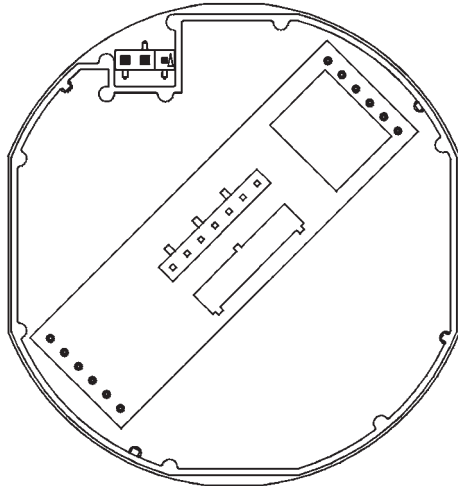

#### Note:

If no jumper is set, the transmitter is write protected.

Write protection

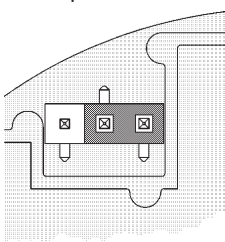

No write protection

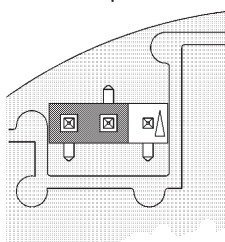

### PROFIBUS / FOUNDATION Fieldbus:

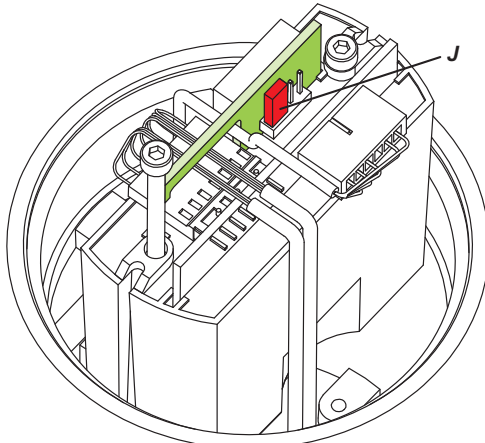

#### No write protection

Jumper **J** connects both left pins (as shown)

#### Write protection

Jumper **J** connects both right pins, or jumper is not set

## 8.2 Setting via local keys

### Operation and functions of local keys

The two local keys 0 % and 100 % are used to set up zero, lower range value, upper range value and damping.

### Amplifier housing with local keys

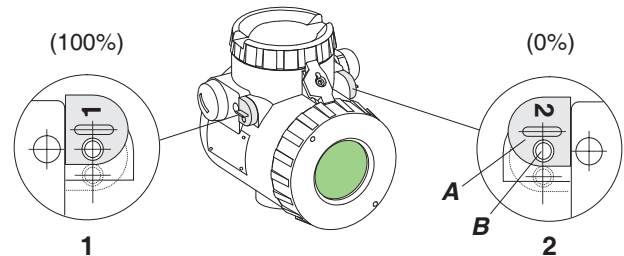

After shifting the key protection cap **A**, insert screw driver or pin ( $\varnothing < 3$  mm) into hole **B** and press down to the second pressure point.

**Both keys have two assigned functions, dependent on length of pressing time.**

#### Damping <sup>1)</sup>

The damping is (electrically) set to 8 sec by manufacturer. With the local keys damping can be adjusted between 0 and 32 sec (90 % time <sup>2)</sup>).

The local display shows the current damping value, when the key 1 is pressed less than 3 sec. Further acting of key 1 stepwise sets the damping.

After damping selection, confirm by short acting key 2.

**Zero, Lower range value and Upper range value**  
see next page

1) Damping is only adjustable with push buttons if local display is provided.

2) 63 % time with HART devices

## Setup of lower and upper range value

### Workshop task

#### Equipment:

- Power supply DC 24V, 30 mA
- Local display configured with mA<sup>1)</sup> resp. % (OUT in %) or multimeter<sup>1)</sup>
- Screw driver ( $\varnothing < 3$  mm)
- Set of standard weights, class M1 <sup>2)</sup>
- Weighing pan <sup>3)</sup> to be suspended in place of displacer

#### Actions:

- Put transmitter in operational position and connect transmitter

#### Setting Zero (not with FoxCom)

Zero point is factory-set. If the zero point shifted by another installation position, it can be corrected as follows:

- Put on weights for Zero point (2.5 kg)
- Press key 2 less than 3 sec.

With HART the output signal is set to 0 (4 mA).

#### Setting Lower range value

- Put on weights for lower range value ( $F_0$ ) <sup>3)</sup>
- Press key 2 more than 5 sec
- Measuring span remains unchanged
- Indicator displays Lower range value

With HART the output current is adjusted to 4 mA.

#### Setting Upper range value

- Put on weights for upper range value ( $F_{100}$ ) <sup>3)</sup>
  - Press key 1 more than 5 sec
  - Lower range value remains unchanged
  - Indicator displays Upper range value
- With HART the output current is adjusted to 20 mA.

#### Wet calibration

If process conditions for lower range value and upper range value can be set during installation it is possible to calibrate installed transmitter.

#### Equipment:

- Local display configured with mA<sup>1)</sup> resp. % (OUT in %) or multimeter<sup>1)</sup>
- Screw driver ( $\varnothing < 3$  mm)

#### Actions:

- Set conditions (e. g. level) for lower range value.
- Press key 2 more than 5 sec.
- Set conditions (e.g. level) for upper range value.
- Press key 1 more than 5 sec.

#### "Warm-up" before calibration

To keep the measuring error at extremely high (or extremely low) process temperatures minimal, it is recommended to have the transmitter reach first the operating temperature.

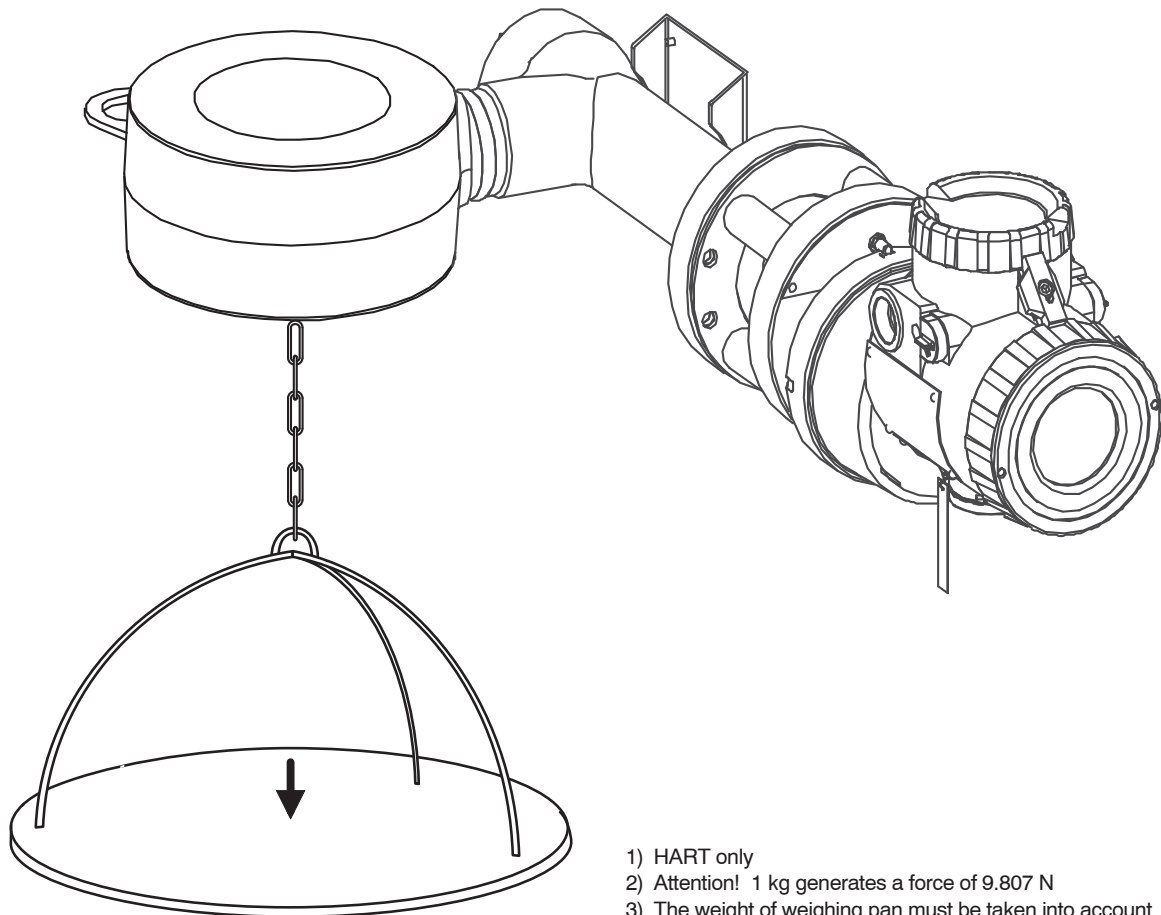

1) HART only

2) Attention! 1 kg generates a force of 9.807 N

3) The weight of weighing pan must be taken into account

### 8.3 Setting via Display Keys

The most important configurations and calibrations can be performed as per menu directly at the transmitter via two keys (NEXT and ENTER).

(The menu structure is identical for the 140 Series with HART/FoxCom or FOUNDATION Fieldbus/ PROFIBUS communication protocols.)

**Note:**

Observe limitations for opening of housing in hazardous areas. See Document "Safety Operating Instructions 140 Series".

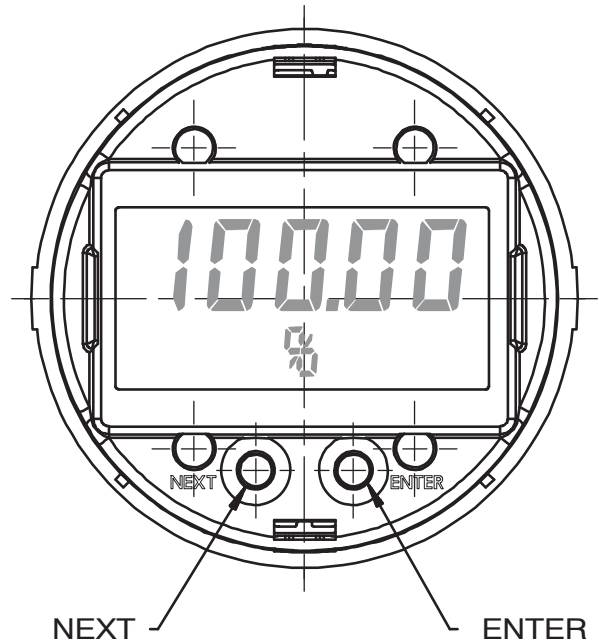

#### Selection in Menu

In selecting a sub-menu the presently selected menu point will be shown first. With key NEXT the following menu point is selected; it is accepted by pressing ENTER.

#### Numerical Input

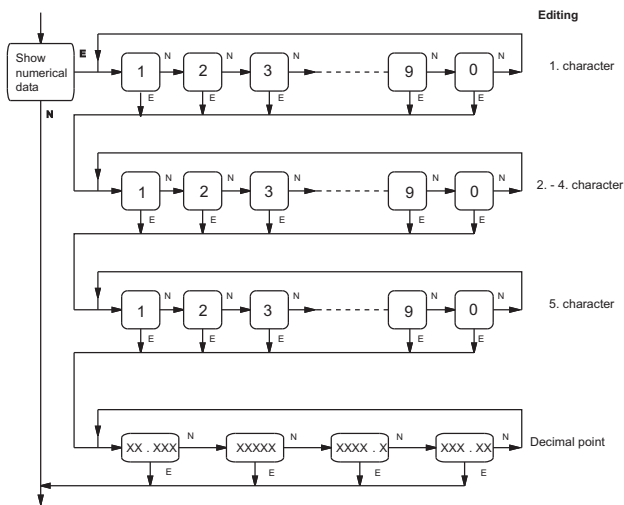

If the menu requests numerical input the current value and name are displayed.

By actuating key NEXT the menu position is exited without changing the value.

Following pressing ENTER the value may be changed by pressing key NEXT and upward counting of the blinking number ('1' follows '0'). ENTER switches to the following position.

Following change and/or activating of all characters (max. 5 digits) input of the decimal point is requested. Key NEXT relocates decimal point. By pressing ENTER the value has been transferred.

Upon transfer the value range is checked. In case of faulty input a blinking error signal is actuated for about 3 seconds (see "Error signals") and is branched to menu node "Cancel".

#### Alphanumeric Input

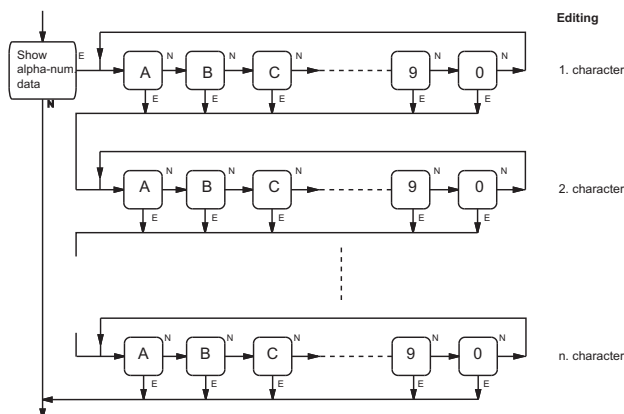

If the menu requests an alpha-numerical input, the presently selected characteristic chain is shown.

By actuating key NEXT this menu position is exited without changing the value.

Following pressing ENTER the value may be changed by pressing key NEXT and upward counting of the blinking characteristic ('A' follows '0'). ENTER switches to the following position.

Following change and/or activation of all characters (max. 5 characters) the character chain is transferred by activating key ENTER.

## 8.4 HART / FoxCom

### Abbreviations:

E ENTER button  
 N NEXT button  
 (with autorepeat: i.e. long, continuous actuation corresponds to multiple single actuations)

The following abbreviations are defined in communication protocol:

### HART/FoxCom:

LRL Lower Range Limit  
 LRV Lower Range Value  
 PV Primary Variable (measured value)  
 URL Upper Range Limit  
 URV Upper Range Value

A branch in the flow charts is called 'node' here.

### Note: Setting with PC20 Software

Beside the in the following described settings with display keys, the PC 20-software still contains large functions (see also MI 020-495):

- Extended configuration
- Calibration of Sensor  
(in the workshop, after exchanging the Sensor)
- Test of Transmitter
- Trend recording

Extended configuration with PC20 contains the access to the 32 X/Y values for the customized characteristic, the access to the alarm limits and the access to flange material and dimensions of the sensor.

In addition the mode can be switched between AUTO/MAN/O/S.

The measured value can be simulated; in Mode MAN the output can be written directly.

The calibration after exchange of the sensor contains both the transmission of the finger print data of the sensor and the sensor alignment with password.

With Test of Transmitter the recorded diagnostic data can be queried. The measured value can be simulated and the output be written directly.

With "Trend" the output of connected device is recorded and displayed.

### 8.4.0 Menu structure

The highest menu level offers sub-menus "Display PV", "Maintenance" and "Special".

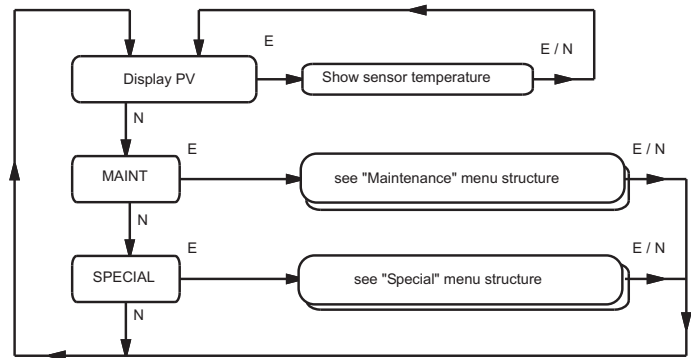

### 8.4.1 Menu node "Display measurement value"

After each pressing the key ENTER alternately is indicated:

- Sensor Temperature in °C or
- the value selected in Menu 8.4.3.5:
  - PV Output value and physical unit
  - PV Output value in %
  - PV Output value in mA
  - No display.



### 8.4.2 Menu node "MAINT"

Branching to "Maintenance" menu (no protection by password).

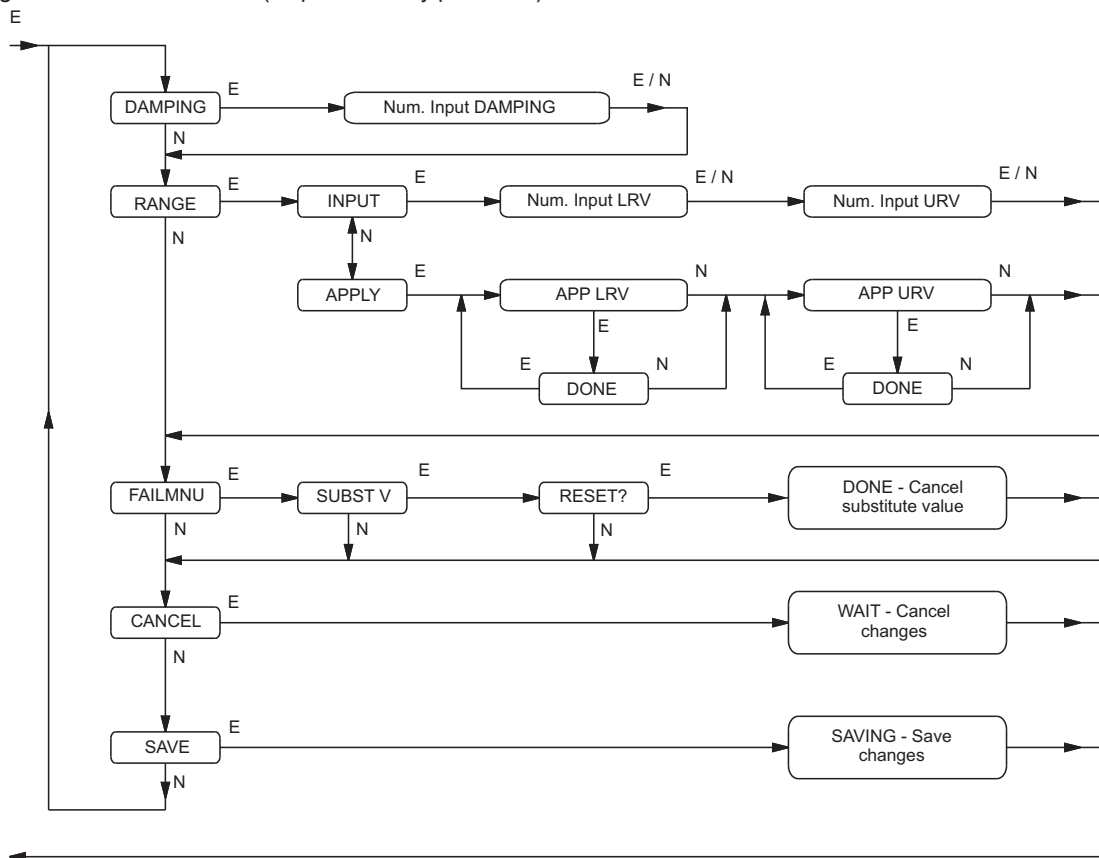

#### 8.4.2.1 Menu node "DAMPING"

Configuration of PV damping.

##### Menu node "Numerical Input DAMPING"

Display / Input of PV damping (phys. unit ,SEC'). The rated value range is 0 ... 32 seconds.

#### 8.4.2.2 Menu node "RANGE"

In node "INPUT" the configuration of Lower Range Value LRV and Upper Range Value URV is entered.

In node "APPLY" the actual current measured value is indicated and confirmed by pressing the ENTER key. The rated value range is LRL...URL.

##### Menu node "INPUT / Numerical input LRV"

Configuration of LRV by input. Normally 0; exception with Zero elevation.

##### Menu node "INPUT / Numerical input URV"

Configuration of URV by input.

##### Menu node "APPLY / APP LRV"

(use only with Zero elevation)

Configuration of LRV by default, the current PV is indicated. Confirm LRV by pressing ENTER key.

##### Menu node "APPLY / APP URV"

Configuration of URV by default, the current PV is indicated. Confirm URV by pressing ENTER key.

#### 8.4.2.3 Menu node "FAILMNU"

Manual take back of configured substitute value.

##### Menu node "SUBST V / RESET?"

Manual take back of configured substitute value. If substitute value is taken back automatically this menu is out of operation.

#### 8.4.2.4 Menu node "CANCEL"

By pressing ENTER key all changes are cancelled.

#### 8.4.2.5 Menu node "SAVE"

By pressing ENTER key all changes are stored.

**8.4.3 Menu node "SPECIAL"**

Branching to "Special" menu. In difference to the "Maintenance" menu it is possible to make extensive configurations. Optional it is possible to configure password protection.

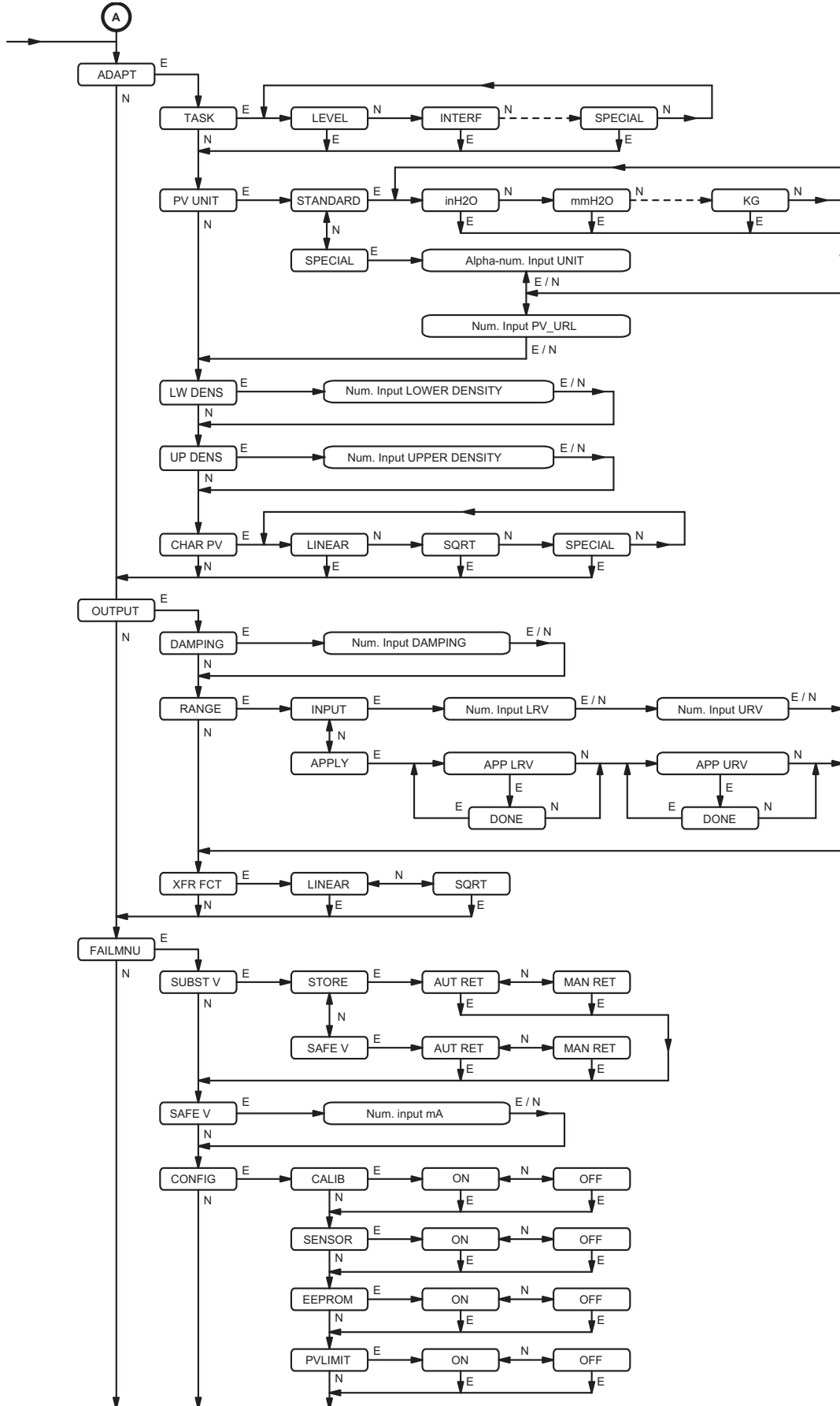

**8.4.3.1 Menu node “ADAPT”**

Branching to configuration for adaptation of sensor measurement value.

**Menu node “TASK”**

Configuration of measurement task. Selection of measuring task in menu. The configured measuring task is of a purely informative character and has no effect on the functionality of the transmitter.

**Menu node “PV UNIT / STANDRD”**

Configuration of standard unit for PV. Selection of the unit in menu. If the new unit can be derived from the old one (e.g. mbar to bar) or if there is a change from unit ‘%’ to a pressure unit, an implicit conversion from LRV and URV takes place. In case old and new units are not identical, URL is set to 0 and has to be entered.

**Menu node “PV UNIT/ SPECIAL”**

Configuration of a special unit for PV. It is possible to define a unit with max. 5 characters (see chap. “Alpha-numeric input”). The Upper Range Limit URL is set to 0 and must be entered.

**Menu node “LW DENS” and “UP DENS”**

Configuration of density (lower and/or upper density) of the measuring product. The configured density is in the unit ‘kg/m<sup>3</sup>’ and is of a purely informative nature having no effect on the functionality of the transmitter.

**Menu node “CHAR PV”**

Configuration of transmitting characteristic of PV. Selection of characteristic in the menu.

LINEAR – linear characteristic

SQRT – square-root extracted characteristic

SPECIAL – customized characteristic

Value pairs X/Y associated with characteristic ‘SPECIAL’ cannot be entered via display menu; input via PC20.

**8.4.3.2 Menu node “OUTPUT”**

Configuration of Output of transmitter.

**Menu node “DAMPING” and “RANGE”**

see “MAINT”.

**Menu node “XFR FCT”**

Configuration of the transfer function of the current output. Selection of transfer function in menu: linear (LINEAR) and square-root extracted (SQRT).

**8.4.3.3 Menu node “FAILMNU”**

Configuration for the behavior in case of an error.

**Menu node “SUBST V / STORE”**

Configuration of the behavior during ‘Store last Value’. In case of an error, the transmitter maintains the last valid output current until the error is eliminated (automatic return, AUT RET) or until the substitute value is manually returned (MAN RET).

**Menu node “SUBST V / SAFE V”**

Configuration of the behavior of the substitute value. In case of an error, the transmitter changes the output current to a configured substitute value and maintains the output current until the error is eliminated (automatic return, AUT RET) or until the substitute value is manually returned (MAN RET).

**Menu node “SAFE V”**

Configuration of the substitute value. The permissible value range is 3.6 to 23 mA. This value is of significance only if the “Substitute value” is configured instead of ‘Store last value’. During an error this configured value becomes the output current of the transmitter.

**Menu node “CONFIG”**

Branching for configuration of malfunctions messages. There are seven areas where a malfunction signal can either be activated (ON) or suppressed (OFF).

- |            |   |
|------------|---|
| 1. CALIB   | Internal calibration failed                       |
| 2. SENSOR  | Sensor value of $\pm 150$ % of nominal range      |
| 3. EEPROM  | Write EEPROM impossible                           |
| 4. PVLIMIT | PV $\pm 110$ % of nominal range                   |
| 5. SENTEMP | Sensor temperature out of limits                  |
| 6. EL TEMP | Electronic temperature outside<br>– 45 °... 85 °C |
| 7. RANGE   | Configured measuring range invalid                |

Menu node "SPECIAL" (continued)

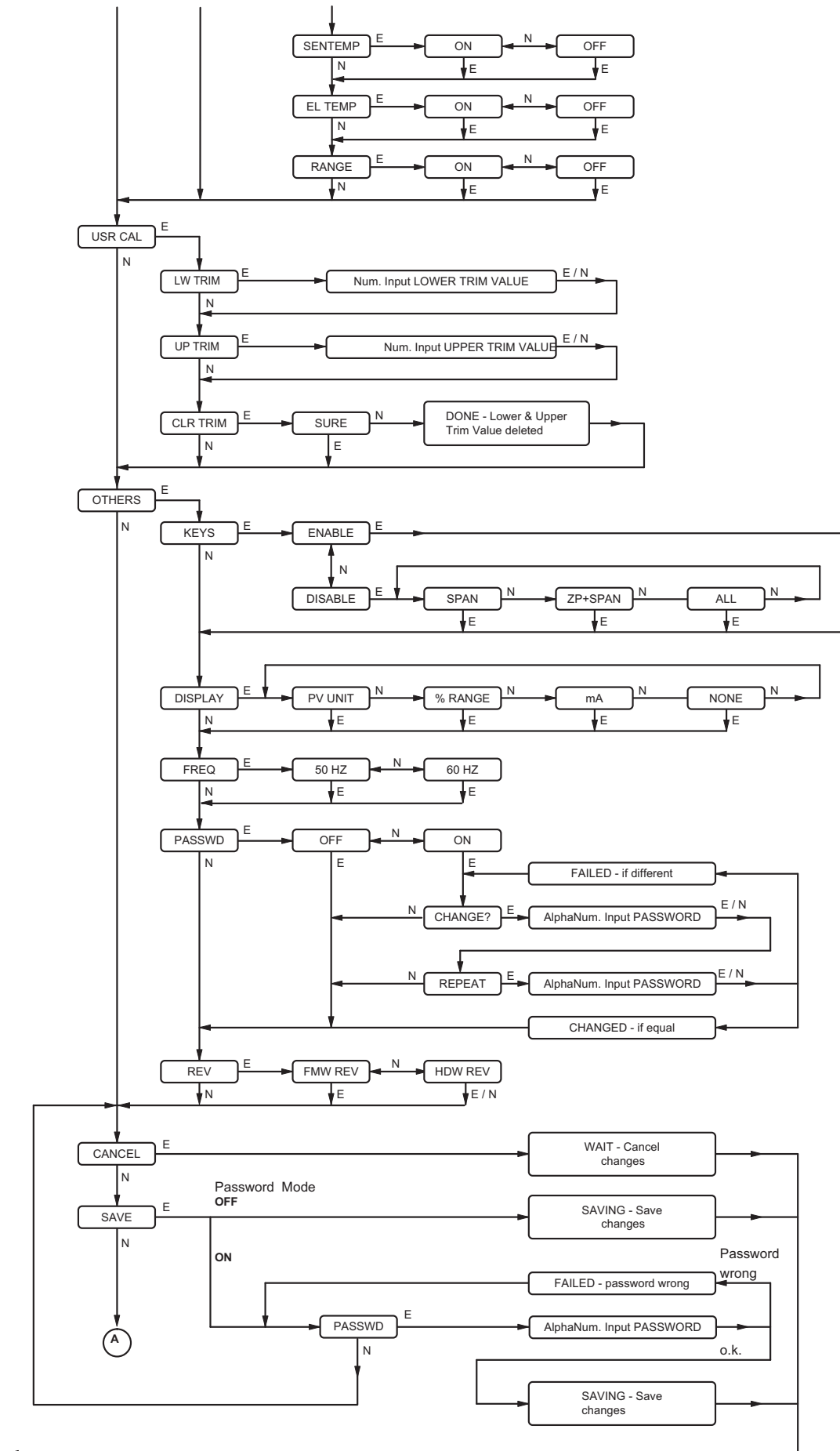

**8.4.3.4 Menu node “USR CAL”**

User calibration of measured value PV.

**Menu node “LW TRIM”**

Calibration of lower trimpoint. Indication of measuring value corresponding to the lower trimpoint and entry of value.

Following entry of trimpoint the transmitter calculates, based on trimpoint and measuring value, a new zeropoint for its transmitting characteristics.

**Menu node “UP TRIM”**

Calibration of upper trimpoint. Indication of measuring value corresponding to upper trimpoint and entry of value.

Following entry of trimpoint the transmitter calculates, based on trimpoint and measuring value, a new zeropoint and new end for its transfer characteristics .

**Menu node “CLRTRIM”**

Delete user calibration (clear trimpoints).

**8.4.3.5 Menu node “OTHERS”****Menu node “KEYS / ENABLE”**

Release of all functions of external keys (1- and 2- key) of transmitter.

**Menu node “KEYS / DISABLE”**

Selective blocking of external keys of transmitter.

SPAN	URV configuration is blocked
ZP+SPAN	LRV + URV configuration is blocked
ALL	All functions are blocked

**Menu node “DISPLAY”**

Configuration of measurement diagram in display.

PV UNIT	Display of value and unit of PV
% RANGE	Display of AO in %
MA	Display of AO in mA
NONE	No display

**Menu node “FREQ”**

Adapt the trouble suppression to line frequency 50 / 60 Hz.

**Menu node “PASSWD”**

Branching into password administration. It is possible to secure storing of changes in the “SPECIAL” menu by a password interrogation, i.e. password interrogation may be activated (ON) or deactivated (OFF). It is possible to change the password during activated password interrogation. Dual input of password confirms the change.

**Menu node “REV”**

Display of firmware and hardware revisions.

**8.4.3.6 Menu node “CANCEL”**

Taking back all changes by pressing ENTER key.

**8.4.3.7 Menu node “SAVE”**

During deactivated password interrogation all changes are stored by pressing ENTER. During activated password interrogation it is necessary to enter the correct password (the old password has to be used in the configuration of a new password) to store all changes .

**8.4.7 Error messages**

The following error messages are possible:

BADDAMP	invalid range of damping
BAD LRV	invalid range of LRV
BAD URV	invalid range of URV
BADSPAN	span   upper trim point – lower trim point   < 2 % of max. admissible span of measurement
BAD PAR	invalid range of upper or lower trim point
BADPROC	invalid value of upper or lower trim point
BAD URL	invalid range of URL
BAD MA	invalid range of output current
WR PROT	transmitter is write protected

If one of this errors occurs, entry it will not be accepted.  
Break-off by activating CANCEL.

**8.4.8 Warning messages**

A configuration that triggers a warning will be accepted and can be assumed via SAVE.

Warnings are:

WRNSPAN	observe extended technical data for turn down > 1:20 (TI EMP0600G-(en))
WRN URV-	invalid range of URV due to indirect configuration.

**8.4.9 Time-out monitoring**

By entering menu node “MAINT” or “SPECIAL” the monitoring of all keys will be started for 120 seconds which will be restarted with each pressing of keys.

By exceeding the monitoring time all previous changes will be canceled and the menu is branching to menu node “Display PV”.

Only the menu steps associated to menu nodes “USR CAL” and “APPLY” are not monitored.

**8.5 PROFIBUS**

**Abbreviations:**

- E ENTER button
- N NEXT button
- (with autorepeat: i.e. long, continuous actuation corresponds to multiple single actuations)

The following abbreviations are defined in communication protocol:

**PROFIBUS:**

- LRL Lower Range Limit
- LRV Lower Range Value
- PV Primary Variable (measured value)
- URL Upper Range Limit
- URV Upper Range Value

A branch in the flow charts is called 'node' here.

**Note: Setting with PC20 Software**

Beside the in the following described settings with display keys, the PC 20-software still contains large functions (see also MI 020-495):

- Extended configuration
- Calibration of Sensor (in the workshop, after exchanging the Sensor)
- Test of Transmitter
- Trend recording

Extended configuration with PC20 contains the access to the 32 X/Y values for the customized characteristic, the access to the alarm limits and the access to flange material and dimensions of the sensor.

In addition the mode can be switched between AUTO/MAN/O/S.

The measured value can be simulated; in Mode MAN the output can be written directly.

The calibration after exchange of the sensor contains both the transmission of the finger print data of the sensor and the sensor alignment with password.

With Test of Transmitter the recorded diagnostic data can be queried. The measured value can be simulated and the output be written directly.

With "Trend" the output of connected device is recorded and displayed.

**8.5.0 Menu structure**

The highest menu level offers sub-menus "Display PV", "Maintenance" and "Special".

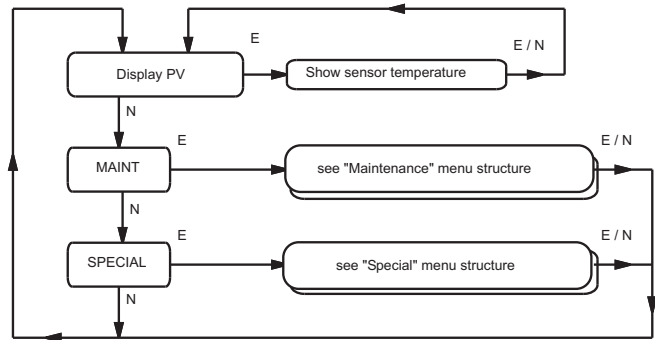

**8.5.1 Menu node "Display measurement value"**

After each pressing the key ENTER alternately is indicated:

- Sensor Temperature in °C or
- the value selected in Menu 8.5.3.5:
  - Measured value PV and physical unit
  - Output value and physical unit
  - No display.

## 8.5.2 Menu node "MAINT"

After Branching to "Maintenance" menu (no protection by password) the following functions are possible:

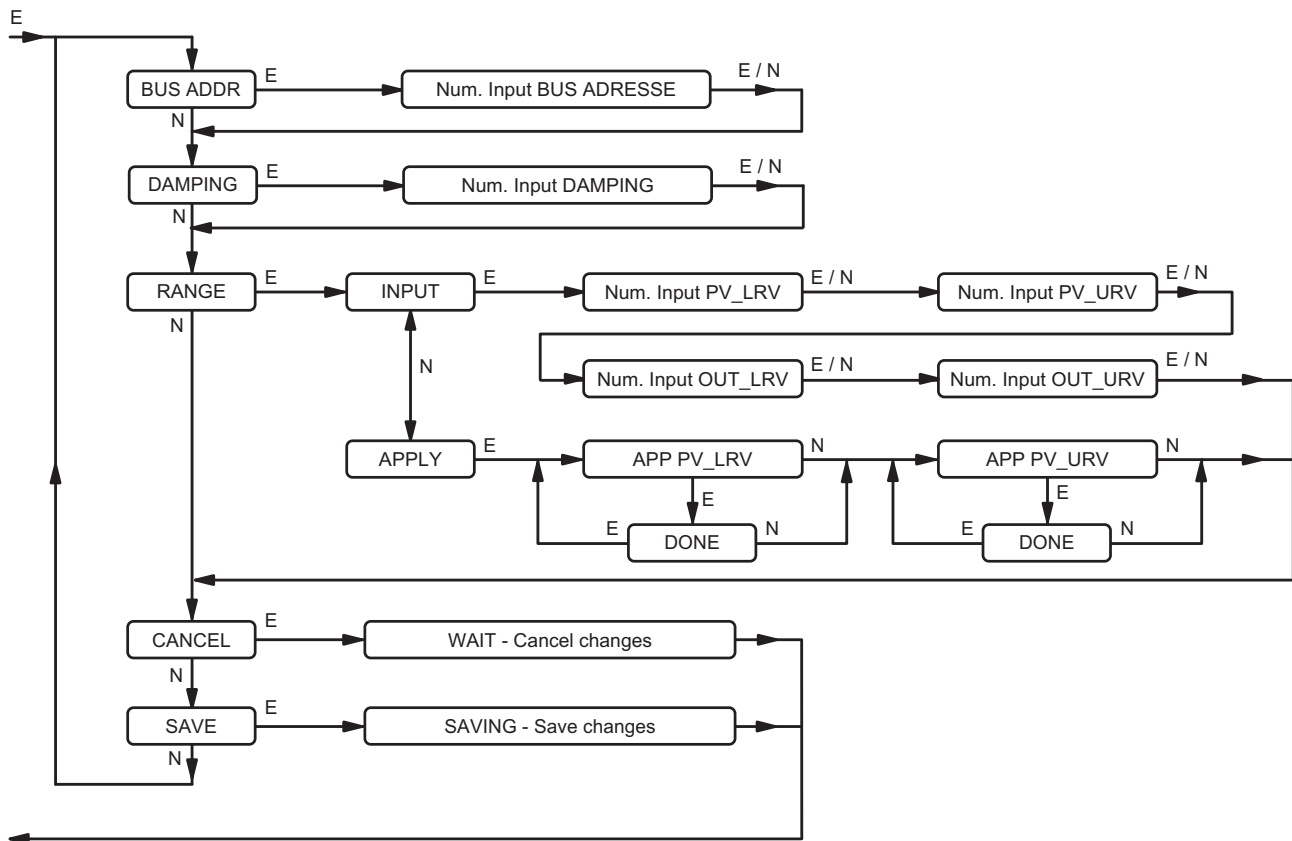

### 8.5.2.1 Menu node "BUS ADDRESS"

Numerical input of Bus Address. The rated value range is 1 ... 125.

### 8.5.2.2 Menu node "DAMPING"

Configuration of output signal damping.

#### "Numerical Input DAMPING"

Display / Input of OUT damping (phys. unit ,SEC'). The rated value range is 0 ... 32 seconds.

### 8.5.2.3 Menu node "RANGE"

In node "INPUT" the Lower/Upper Range Value PV\_LRV / PV\_URV and the Lower/Upper Output Value OUT\_LRV / OUT\_URV is configured.

In node "APPLY" the actual current measured value is indicated and confirmed by pressing the ENTER key. The rated value range is LRL...URL.

#### "INPUT / Numerical input PV\_LRV"

Configuration of PV\_LRV by numerical input. Normally 0; exception with Zero elevation.

#### "INPUT / Numerical input PV\_URV"

Configuration of PV\_URV by input.

#### "INPUT / Numerical input OUT\_LRV" <sup>1)</sup>

Configuration of OUT\_LRV by input.

#### "INPUT / Numerical input OUT\_URV" <sup>1)</sup>

Configuration of OUT\_URV by input.

#### "APPLY / APP PV\_LRV"

(use only with Zero elevation)

Configuration of PV\_LRV by default, the current PV is indicated. Confirm PV\_LRV by pressing ENTER key.

#### "APPLY / APP PV\_URV"

Configuration of PV\_URV by default, the current PV is indicated. Confirm PV\_URV by pressing ENTER key.

### 8.5.2.4 Menu node "CANCEL"

By pressing ENTER key all changes are cancelled.

### 8.5.2.5 Menu node "SAVE"

By pressing ENTER key all changes are stored.

1) After input the alarm limits are set to standard values:

hi = 100 %, hihi = 110 %, lo = 0 %, lolo = -10 %, hysteresis 0.5 %  
For unit of OUT see display.

### 8.5.3 Menu node "SPECIAL"

Branching to "Special" menu. In difference to the "Maintenance" menu it is possible to make extensive configuration. Optional it is possible to configure the password protection.

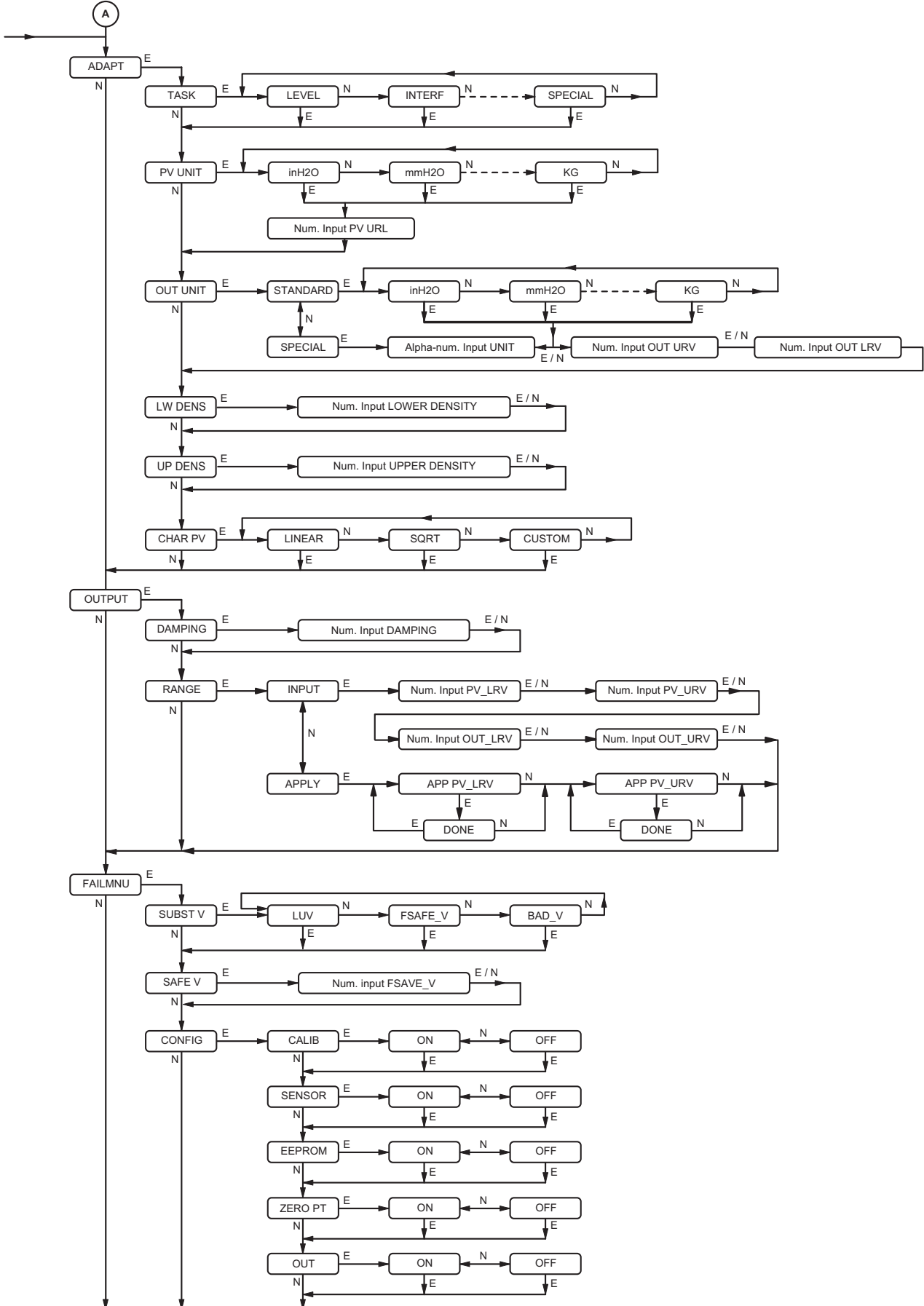



**8.5.3.1 Menu node “ADAPT”**

Configuration for adaptation of sensor measurement value.

**Menu node “PRV UNIT”**

Configuration of standard unit for PV. Selection of the unit in menu. In case old and new units are not identical, PV\_URL is set to 0 and has to be entered.

**Menu node “OUT UNIT / STANDARD”**

Configuration of a standard unit for output value OUT. Selection of the unit in menu. If old and new unit are not identical OUT\_LRV and OUT\_URL are set to 0 and must be entered.

Alarm limit values see "MAINT".

**Menu node “OUT UNIT / SPECIAL”**

Configuration of a special unit for output value OUT. Definition of an unit with up to 5 characters. OUT\_LRV and OUT\_URL are set to 0 and must be entered.

**Menu node “LW DENS” and “UP DENS”**

Configuration of density (lower density and/or upper density) of the measuring product. The configured density is in the unit 'kg/m<sup>3</sup>' and is of a purely informative nature having no effect on the functionality of the transmitter.

**Menu node “CHAR PV”**

Configuration of transmitting characteristic of measured value PV. Selection of characteristic in the menu.

LINEAR – linear characteristic

SQRT – square-root extracted characteristic

CUSTOM – customized characteristic

Value pairs X/Y associated with characteristic 'CUSTOM' cannot be entered via display menu but via PC20 Software.

**8.5.3.2 Menu node “OUTPUT”**

Configuration of output of transmitter.

**Menu node “DAMPING” and “RANGE”**

see “MAINT”

**Menu node “XFR FCT” (not with level devices)**

(ON/OFF of Low Cut for flow transmitters)

**8.5.3.3 Menu node “FAILMNU”**

Configuration of the reactions to errors.

**Menu node “SUBST V / LUV”**

Configuration of the behavior during 'Hold last Value'. In case of an error, the transmitter maintains the last valid output value until the error is eliminated (automatic return).

**Menu node “SUBST V / FSAFE\_V”**

Configuration of the behavior of the 'substitute value'. In case of an error, the transmitter changes the output value to a configured substitute value and maintains the output value until the error is eliminated (automatic return).

**Menu node “SUBST V / BAD\_V”**

Configuration 'wrong value'.

During an error the output of transmitter shows the wrong value. Failsafe is shown.

**Menu node “SAFE V”**

Configuration of the substitute value.

This value is of significance only if the "Substitute value" FSAFE\_V is configured. During an error this configured value becomes the output current of the transmitter. The permissible value range is -10 ... +110 %.

**Menu node “CONFIG”**

Branching for configuration of fault signal messages.

For the following nodes a fault signal message can become activated (ON) or suppressed (OFF):

CALIB	Internal calibration failed
SENSOR	Sensor value out of nominal range (+ / -150 %)
EEPROM	Write to EEPROM impossible
ZERO PT	Zero point out of sensor limits (+ / -150 %)
OUT	Measured value out of OUT ranging limits (+ / -110 %)
SENTEMP	Sensor temperature out of limits - 60 °... 220 °C
EL TEMP	Electronic temperature out of limits - 45 °... 85 °C
RANGE	Configured measuring range invalid

Menu node "SPECIAL" (continued)

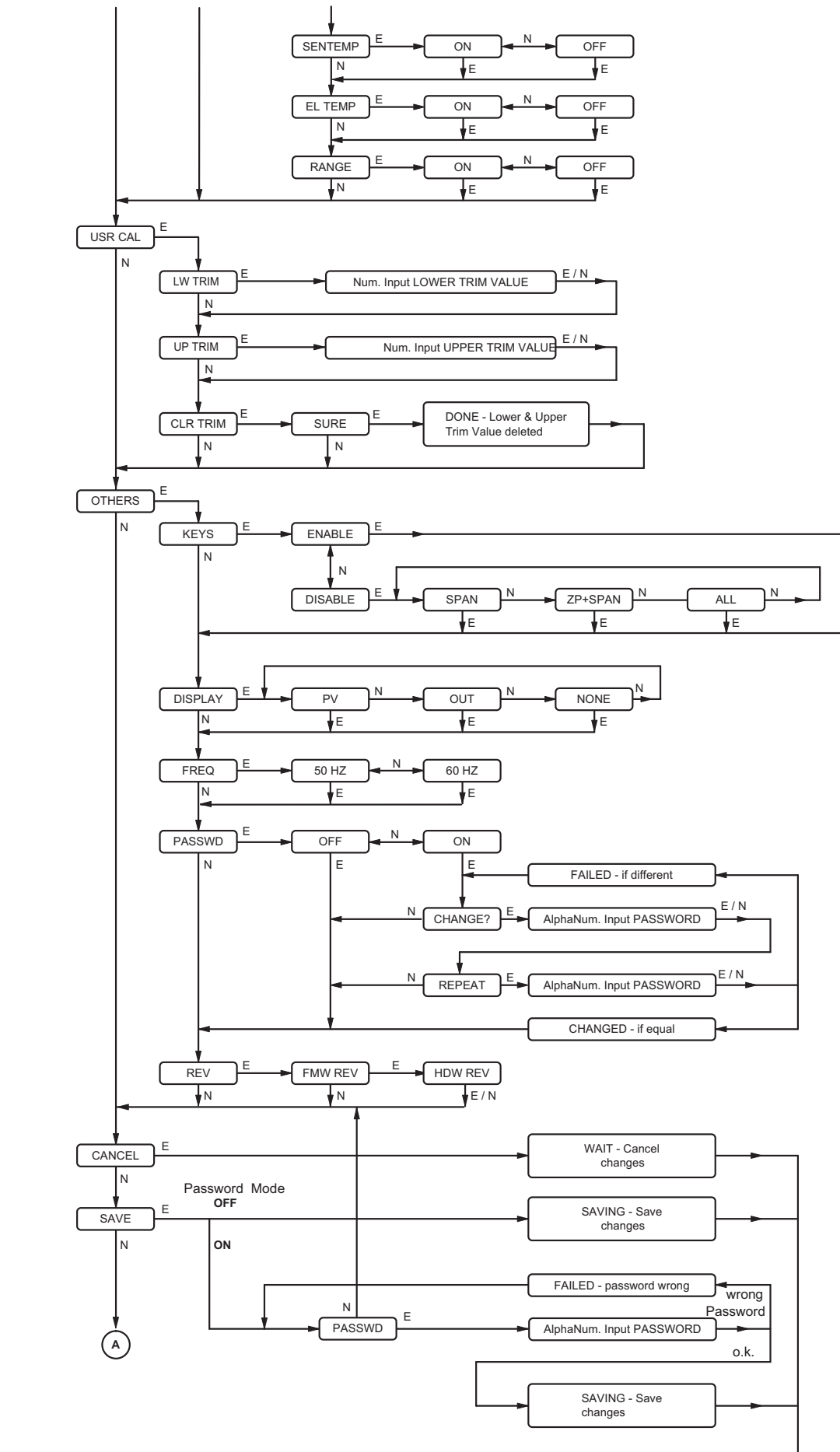

**8.5.3.4 Menu node “USR CAL”**

Custom calibration of measured value PV (see also flow diagram).

**Menu node “LW TRIM”**

Calibration of lower trimpoint (Cal\_Point\_lo). Indication of measuring value corresponding to the lower trimpoint, and entry of value. Following entry of trimpoint the transmitter calculates, based on trimpoint and measuring value, a new zero point for its transmitting characteristics.

**Menu node “UP TRIM”**

Calibration of upper trimpoint (Cal\_Point\_hi). Indication of measuring value corresponding to upper trimpoint and entry of value. Following entry of trimpoint the transmitter calculates, based on trimpoint and measuring value, a new zero point for its transmitting characteristics.

**Menu node “CLRTRIM”**

Delete custom calibration (clear trimpoints).

**8.5.3.5 Menu node “OTHERS”****Menu node “KEYS / ENABLE”**

Release of all functions of external keys (1- and 2- button) of transmitter.

**Menu node “KEYS / DISABLE”**

Selective blocking of external keys (in transmitter housing):

SPAN	Configuration Upper Range Value blocked
ZP+SPAN	Configuration Upper Range Value and configuration Lower Range Value blocked
ALL	All functions are blocked

**Menu node “DISPLAY”**

Configuration of presentation of the value in the display:

PV	Display of value and unit of measured value PV
OUT	Display of value and unit of Output
NONE	No display

**Menu node “FREQ”**

Select the line frequency noise suppression filter 50 / 60 Hz

**Menu node “PASSWD”**

Password administration.

It is possible to secure storing of changes in the “SPECIAL” menu by a password interrogation, i.e. password interrogation may be activated (ON) or deactivated (OFF).

It is possible to change the password during activated password interrogation. Dual input affects the change.

The device is shipped without password (OFF).

**Menu node “REV”**

Display of firmware and hardware revisions.

**8.5.3.6 Menu node “CANCEL”**

Taking back all changes by pressing ENTER.

**8.5.3.7 Menu node “SAVE”**

During deactivated password interrogation all changes are stored by pressing ENTER. During activated password interrogation it is necessary to enter the correct password (the old password has to be used in the configuration of a new password) to store all changes.

**8.5.4 Error messages**

The following error messages can appear at display:

BADDAMP	invalid range of damping <sup>1)</sup>
BAD LRV	invalid range of Lower range value PV_LRV <sup>2)</sup>
BAD URV	invalid range of Upper range value PV_URV <sup>2)</sup>
BADSPAN	span   upper trim point – lower trim point   < 2 % of max. admissible span of measurement
BAD PAR	invalid range of upper or lower trim point <sup>3)</sup>
BADPROC	invalid value of upper or lower trim point <sup>3)</sup>
BAD FSV	invalid substitution value
BAD URL	invalid range of URL
WR PROT	Transmitter is write protected

If one of this errors occurs, entry will not be accepted. Break-off by activating CANCEL.

**8.5.5 Warning messages**

A configuration, which causes a warning, is accepted and can be assumed by means of "SAVE".

Warnings are:

WRNSPAN	observe extended technical data for turn down > 1:20 (see TI EML0610P)
WRN URV	invalid range when changing Lower Range Value
LO DISA	Local operation disabled (Local keys blocked)
DB LOCK	Data base blocked; Hardware write protected

**8.5.6 Time-out monitoring**

By entering menu node “MAINT” or “SPECIAL” the monitoring of all keys will be started for 120 seconds which will be restarted with each pressing of keys.

By exceeding the monitoring time all previous changes will be canceled and the menu is branching to menu node “Display PV”.

Only the menu steps associated to menu nodes “USR CAL” and “APPLY” are not monitored.

1) Is <0 or >32

2) Is out of PV\_URL and PV\_LRL

3) Is < -110 % or > +110 % of Sensor\_Value, see flow diagram

## 8.6 FOUNDATION Fieldbus

### Abbreviations:

E ENTER button  
 N NEXT button  
 (with autorepeat: i.e. long, continuous actuation corresponds to multiple single actuations)

The following abbreviations are defined in communication protocol:

#### FOUNDATION Fieldbus:

LRL Lower Range Limit PRV  
 LRV Lower Range Value XD\_Scale  
 LRV Lower Range Value OUT\_Scale  
 PV Process Value  
 PRV Primary Value  
 URL Upper Range Limit PRV  
 URV Upper Range Value XD\_Scale  
 URV Upper Range Value OUT\_Scale

A branch in the flow charts is called 'node' here.

### 8.6.0 Menu structure

The highest menu level offers sub-menus "Display measurement value", "Maintenance" and "Special".

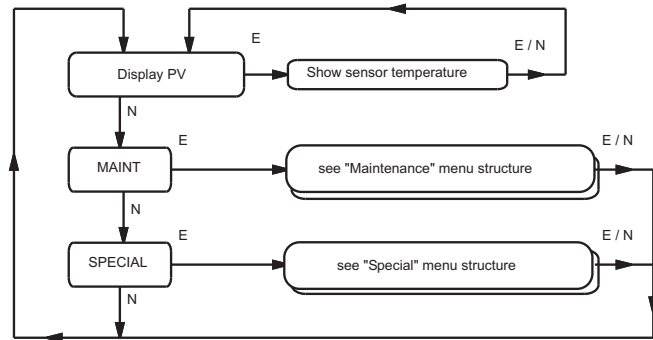

### 8.6.1 Menu node "Display measurement value"

After each pressing the key ENTER alternately is indicated:

- Sensor Temperature in °C or
- the value selected in Menu 8.6.3.3:
  - Measured value PRV and physical unit
  - Output value and physical unit
  - No display.

## 8.6.2 Menu node "MAINT"

After Branching to "Maintenance" menu (no protection by password) the following functions are possible:

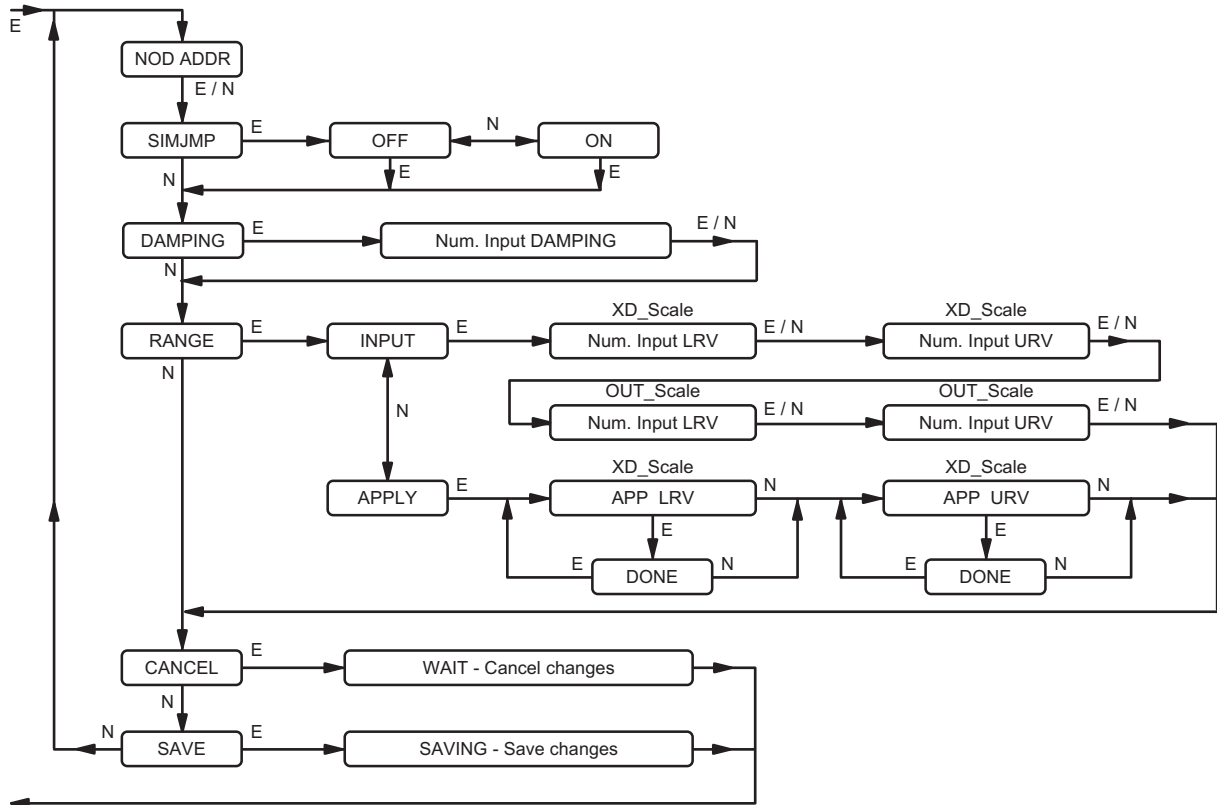

### 8.6.2.1 Menu node "NODE ADDRESS"

Shows address of device. Not changeable.

### 8.6.2.2 Menu node "SIM JMP"

Simulates a "jumper". Simulation of PRIMARY\_VALUE via external configurator when ON.

### 8.6.2.3 Menu node "DAMPING"

Configuration of output signal damping.

#### "Numerical Input DAMPING" (PV\_FTime)

Display / Input of OUT damping (phys. unit ,SEC'). The rated value range is 0 ... 32 seconds.

### 8.6.2.4 Menu node "RANGE"

Configuration of LRV and URV of XD\_Scale and OUT\_Scale.

In node "INPUT" the values can be entered.

In node "APPLY" the actual measured is shown and confirmed by means of the ENTER key.

The value has to be in the range between LRL and URL.

#### "INPUT / Numerical input LRV" of XD\_Scale

Configuration of LRV by numerical input. Normally 0; exception with Zero elevation.

#### "INPUT / Numerical input URV" of XD\_Scale

Configuration of URV by numerical input.

#### "INPUT / Numerical input LRV" of OUT\_Scale

Configuration of LRV by input. Alarm limits are set automatically to LRV and  $LRV - (URV - LRV) * 0.1$

#### "INPUT / Numerical input URV" of OUT\_Scale

Configuration of URV by input. Alarm limits are set automatically to URV and  $URV + (URV - LRV) * 0.1$

#### "APPLY / APP LRV" of XD\_Scale

(use only with Zero elevation)

Configuration of LRV by default, the current PRIMARY\_VALUE is indicated. LRV is confirmed by pressing ENTER key.

#### "APPLY / APP URV" of XD\_Scale

Configuration of URV by default, current PRIMARY\_VALUE is indicated). URV is confirmed by pressing ENTER key. OUT\_SCALE remains unchanged.

### 8.6.2.5 Menu node "CANCEL"

By pressing ENTER key all changes are cancelled.

### 8.6.2.6 Menu node "SAVE"

By pressing ENTER key all changes are stored.

**8.6.3 Menu node "SPECIAL"**

Branching to "Special" menu. In difference to the "Maintenance" menu it is possible to make extensive configuration. Optional it is possible to configure the password protection.

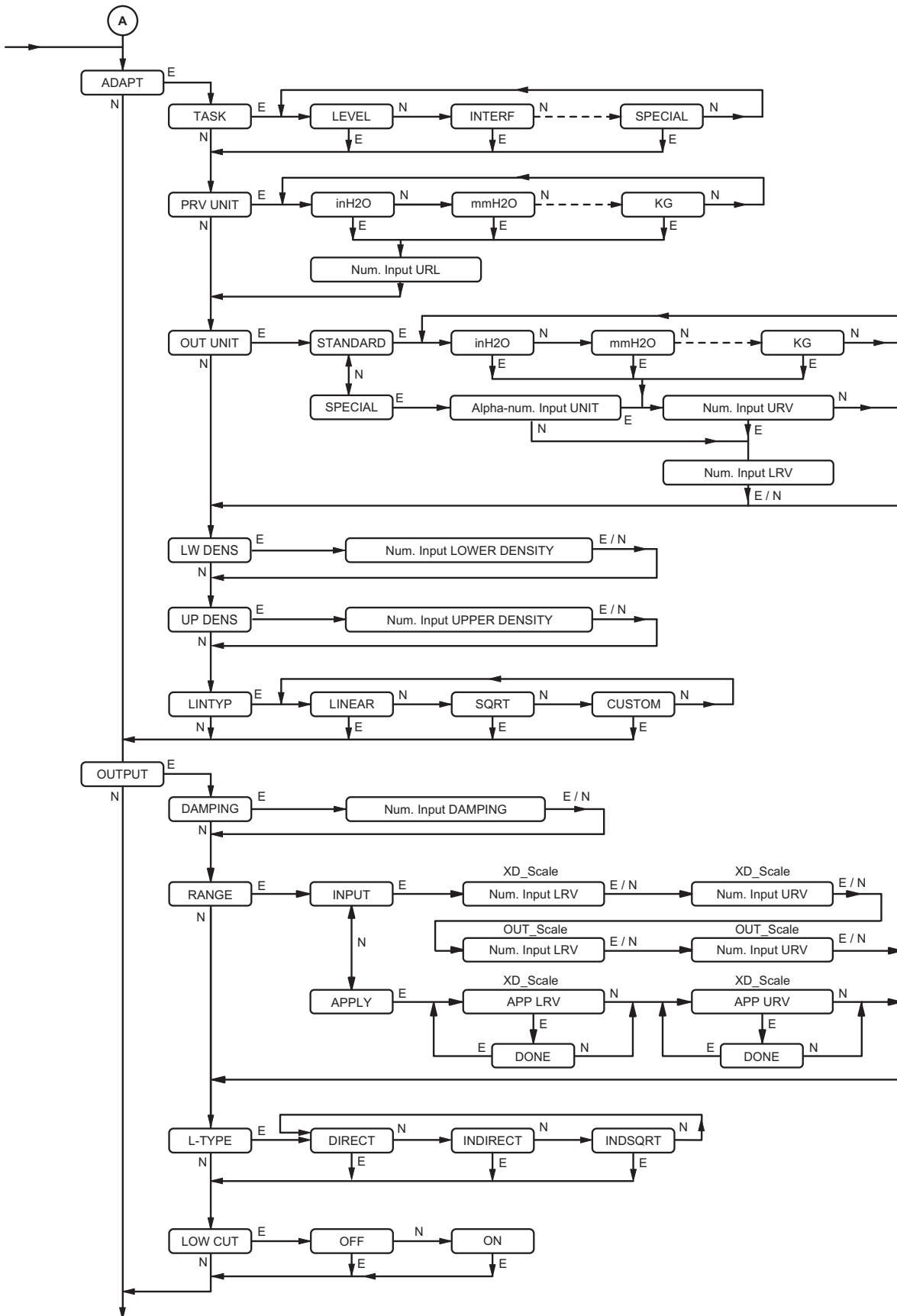

**8.6.3.1 Menu node "ADAPT"**

Configuration for adaptation of sensor measurement value.

**Menu node "TASK"**

Configuration of measurement task. Selection of measuring task in menu. The configured measuring task is of a purely informative character and has no effect on the functionality of the transmitter (Primary value type).

**Menu node "PRV UNIT"**

Configuration of a standard unit for measured value PRV. Selection of the unit in menu. In case old and new units are not identical, URL is set to 0 and has to be entered.

**Menu node "OUT UNIT / STANDARD"**

Configuration of a standard unit for output value OUT. Selection of the unit in menu. If old and new unit are not identically LRV and URL are set to 0 and must be entered.

**Menu node "OUT UNIT / SPECIAL"**

Configuration of a special unit for output value OUT. Definition of an unit with up to 5 characters. LRV and URL are set to 0 and must be entered.

**Menu node "LW DENS" and "UP DENS"**

Configuration of density (lower density and/or upper density) of the measuring product. The configured density is in the unit 'kg/m<sup>3</sup>' and is of a purely informative nature having no effect on the functionality of the transmitter.

**Menu node "LIN TYP"**

Configuration of transmitting characteristic of measured value PRV. Selection of characteristic in the menu:  
 LINEAR – linear characteristic  
 SQRT – square-root extracted characteristic  
 CUSTOM – customized characteristic  
 Value pairs X/Y associated with characteristic 'CUSTOM' cannot be entered via display menu.

**8.6.3.2 Menu node "OUTPUT"**

Configuration of transmitter output.

**Menu node "DAMPING" and "RANGE"**

see "MAINT" 8.6.2.3 and 8.6.2.4

**Menu node "L-TYPE"**

Configuration of transmitting characteristic of Process value PV. Selection of characteristic in the menu:  
 DIRECT OUT/PV is measured value PRV (XD-Scale)  
 INDIRECT OUT/PV is output value (OUT\_Scale)  
 IND SQRT OUT/PV is root-extracted output value (OUT\_Scale) see Block diagram

**Menu node "LOW CUT"**

ON/OFF for small quantity suppression at output with square root of PV. Works to the value after characteristics. With level LOW CUT is set to 0.

Menu node "SPECIAL" (continued)

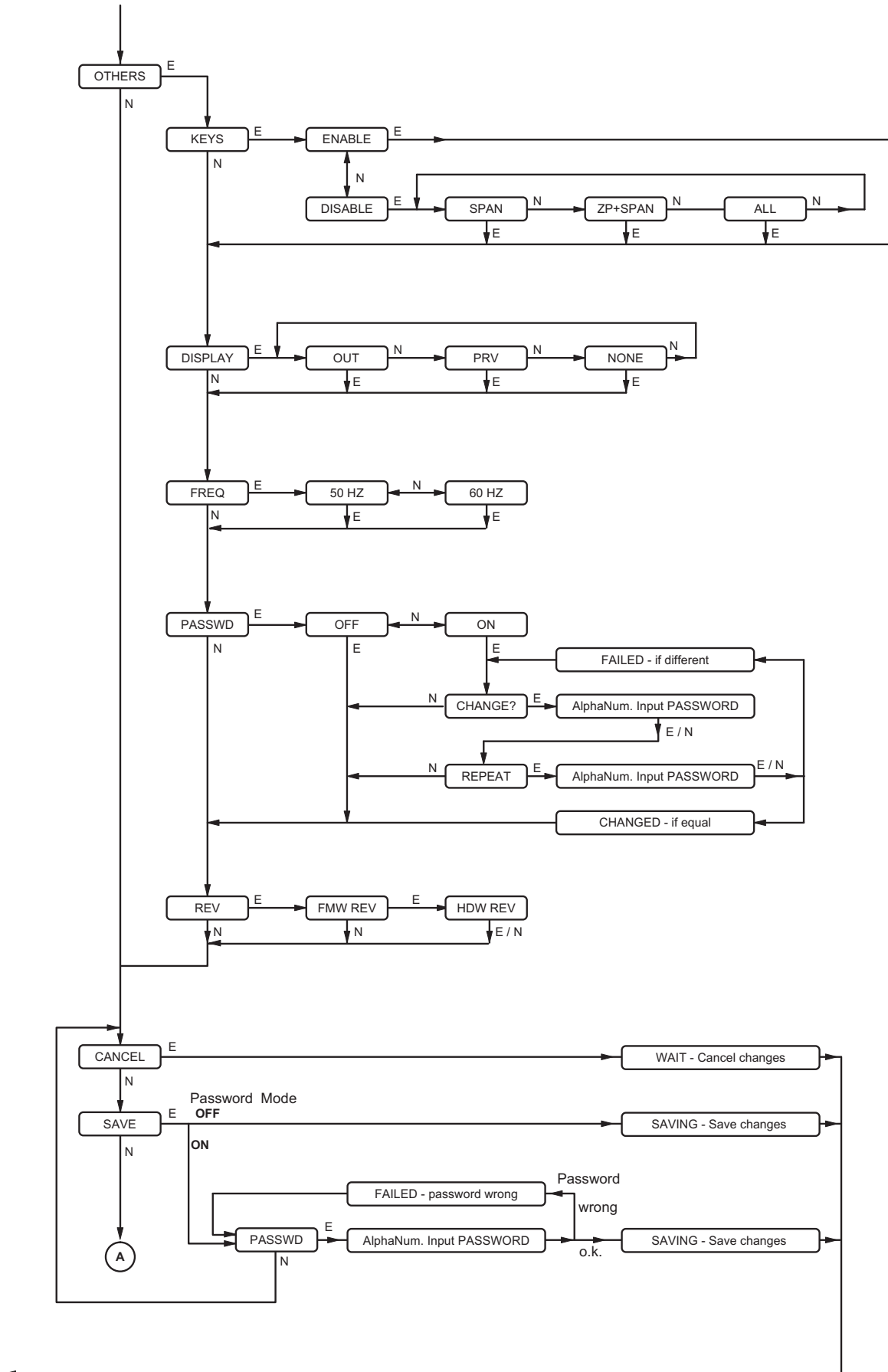



**8.6.3.3 Menu node "OTHERS"****Menu node "KEYS / ENABLE"**

Release of all functions of external keys (1- and 2- button) of transmitter.

**Menu node "KEYS / DISABLE"**

Selective blocking of external keys (in transmitter housing):  
 SPAN Configuration URV blocked (XD\_Scale)  
 ZP+SPAN Configuration LRV + URV blocked (XD\_Scale)  
 ALL All functions are blocked

**Menu node "DISPLAY"**

Configuration of presentation of the value in the display:  
 PRV Display of value and unit of measured value PRV  
 OUT Display of value and unit of Output  
 NONE No display

**Menu node "FREQ"**

Select the line frequency noise suppression filter 50 / 60 Hz.

**Menu node "PASSWD"**

Password administration.

It is possible to secure storing of changes in the "SPECIAL" menu by a password interrogation, i.e. password interrogation may be activated (ON) or deactivated (OFF).  
 It is possible to change the password during activated password interrogation. Dual input affects the change.

**Menu node "REV"**

Display of firmware and hardware revisions.

**8.6.3.4 Menu node "CANCEL"**

Taking back all changes by pressing ENTER.

**8.6.3.5 Menu node "SAVE"**

During deactivated password interrogation all changes are stored by pressing ENTER. During activated password interrogation it is necessary to enter the correct password (the old password\* has to be used in the configuration of a new password) to store all changes.

**8.6.4 Error messages**

The following error messages can appear at display:

BADDAMP	invalid range of damping <sup>1)</sup>
BAD LRV	invalid range of Lower range value LRV <sup>2)</sup>
BAD URV	invalid range of Upper range value URV <sup>2)</sup>
BADSPAN	Span OUT OUT= (URV – LRV) = 0
BAD ZERO	Zero point out of calibrated Sensor_Value of $\pm 110\%$
BADPROC	invalid value of upper or lower trim point <sup>3)</sup>
OP DISA	local operation is disabled (local keys are blocked)
BAD URL	invalid range of PRV_URL
WR LOCK	Transmitter is write protected

If one of this errors occurs, entry will not be accepted.  
 Break-off by activating CANCEL.

**8.6.5 Warning messages**

A configuration, which causes a warning, is accepted and can be assumed by means of "SAVE".

Warnings are:

WRNSPAN	observe extended technical data for turn down > 1:20 (see TI EML0610Q)
WRN URV	invalid range of URV due to indirect configuration (XD_URV > URL).

**8.6.6 Time-out monitoring**

By entering menu node "MAINT" or "SPECIAL" the monitoring of all keys will be started for 120 seconds which will be restarted with each pressing of keys.

By exceeding the monitoring time all previous changes will be canceled and the menu is branching to menu node "Display measured value".

Only the menu steps associated to menu node "APPLY" are not monitored.

\*) Ex factory the password is "WKSHOP"

1) Is <0 or >32

2) Is out of PRV

3) Is < -110 % or > +110 % of Sensor Value

## 9 DIMENSIONING OF DISPLACER

### CALCULATING WEIGHT FORCES (also see VDI/VDE-Guideline 3519, sheet 1)

#### Displacer length = measuring range

Measurement type	Weight forces		0 %	100 %
	Lower range value = 0 % output signal	Upper range value = 100 % output signal		
Liquid level ( $\rho_2$ = negligible)	$F_0 = F_G$	$F_{100} = F_G - V \cdot g \cdot \rho_1$		
Interface ( $\rho_2$ = not negligible)	$F_0 = F_G - V \cdot g \cdot \rho_2$			
Density ( $\rho_2$ = min. density, $\rho_1$ = max. density)				

#### Displacer length > measuring range (without elevation)

Measurement type	Weight forces		0 %	100 %
	Lower range value = 0 % output signal	Upper range value = 100 % output signal		
Liquid level ( $\rho_2$ = negligible)	$F_0 = F_G$	$F_{100} = F_G - V \cdot g \cdot \rho_1 \cdot \frac{h_b}{L}$		
Interface ( $\rho_2$ = not negligible)	$F_0 = F_G - V \cdot g \cdot \rho_2$	$F_{100} = F_G - V \cdot g \cdot (\rho_1 \cdot \frac{h_b}{L} + \rho_2 \cdot \frac{L - h_b}{L})$		

#### Displacer length > measuring range (with elevation)

Measurement type	Weight forces		0 %	100 %
	Lower range value = 0 % output signal	Upper range value = 100 % output signal		
Liquid level ( $\rho_2$ = negligible)	$F_0 = F_G - V \cdot g \cdot \rho_1 \cdot \frac{h_0}{L}$	$F_{100} = F_G - V \cdot g \cdot \rho_1 \cdot \frac{h_0 + h_b}{L}$		
Interface ( $\rho_2$ = not negligible)	$F_0 = F_G - V \cdot g \cdot (\rho_1 \cdot \frac{h_0}{L} + \rho_2 \cdot \frac{L - h_0}{L})$	$F_{100} = F_G - V \cdot g \cdot (\rho_1 \cdot \frac{h_0 + h_b}{L} + \rho_2 \cdot \frac{L - h_b - h_0}{L})$		

- $F_G$  [ N ] Weight force of displacer in atmosphere
- $F_0$  [ N ] Weight force action on suspension point of displacer at lower range value
- $F_{100}$  [ N ] Weight force action on suspension point of displacer at upper range value
- $F_A$  [ N ] Buoyancy force of displacer ( $F_A = F_0 - F_{100}$ )
- $V$  [ m<sup>3</sup> ] Displacer volume (specified on data label in cm<sup>3</sup>)

- $\rho_1$  [ kg/m<sup>3</sup> ] Liquid density
- $\rho_2$  [ kg/m<sup>3</sup> ] Density of gas or lighter liquid
- $g$  [ m/s<sup>2</sup> ] Local acceleration due to gravity (e.g. 9.807 m/s<sup>2</sup>)
- $L$  [ m ] Displacer length
- $h_0$  [ m ] Lower range value
- $h_b$  [ m ] Measuring span

**Attention:** 1 kg generates a force of 9.807 N

1)  $\rho_2$  is negligible if  $\rho_2$  = gas at atmospheric pressure or with ratio  $\rho_2 : \rho_1$  less than 0.5 %.

**Graph for determining displacer diameter**

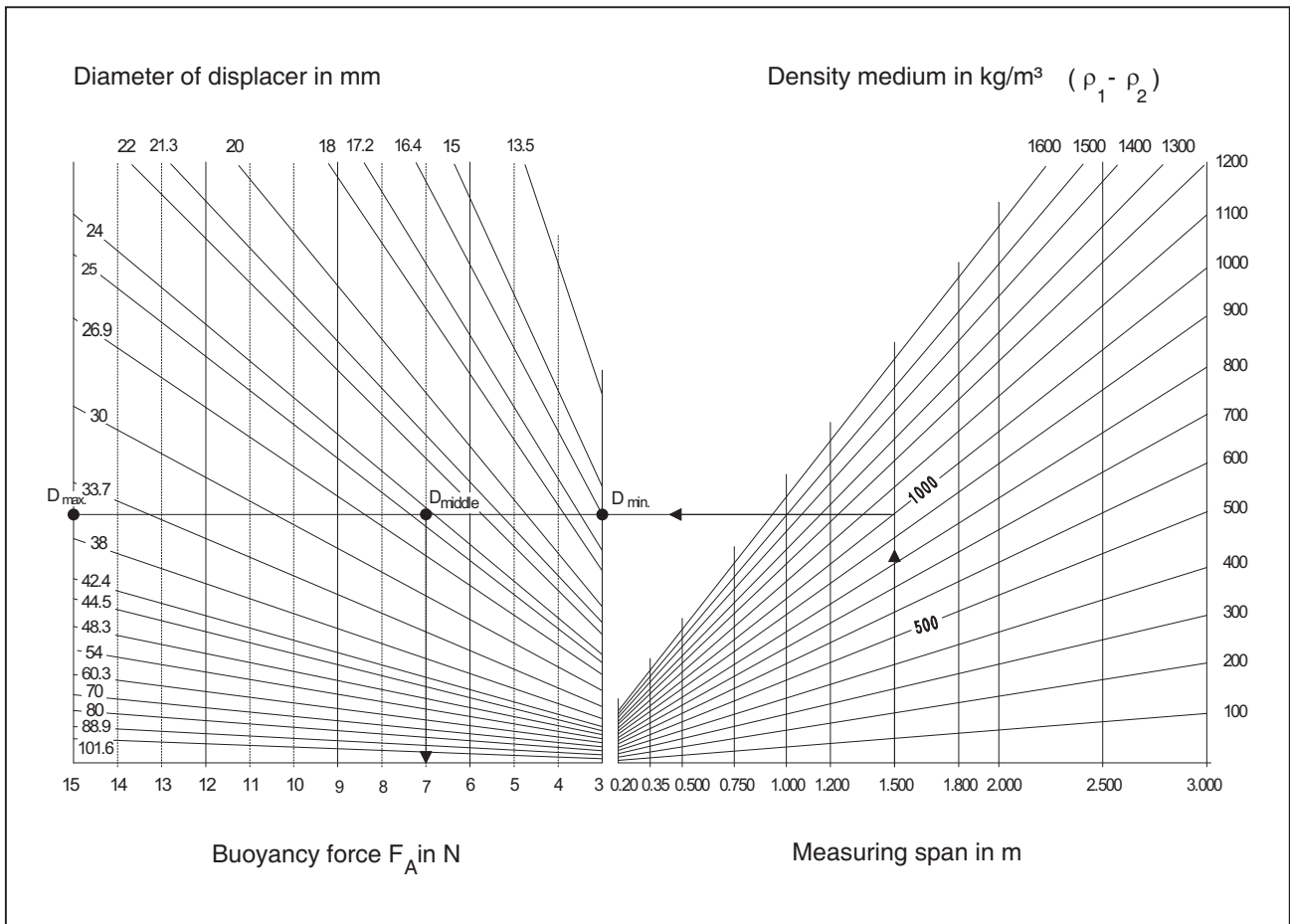

**Measuring span**

The transmitter is designed for a buoyancy force measuring span of minimum 2 up to maximum 20 N.

**Weight force**

The maximum weight of the displacer  $F_G$  max. is 40 N for level measurements. For density or interface measurements, the displacer must be dimensioned so that after deducting  $F_A$  of the lighter process media, the remaining force  $F_0$  does not exceed 40 N.

**Determining displacer diameters**

For optimum use of the transmitter, the displacer should be dimensioned so that the greatest possible buoyancy force is generated over the measuring range. On the other hand, the maximum possible diameter of the displacer must be taken into consideration.

In the above graph the displacer diameter can easily be estimated dependent on the measuring span and the buoyancy force.

The following equation can be used to exactly dimension the displacer:

$$D = 1000 \sqrt{\frac{4 F_A}{\pi g (\rho_1 - \rho_2) L}} \quad [ \text{mm} ]$$

- $D$  = Outside diameter of displacer in mm
- $F_A$  = Buoyancy force of displacer in N
- $g$  = Acceleration due to gravity (9.807 m/s<sup>2</sup>)
- $\rho_1$  = Density of heavier liquid in kg/m<sup>3</sup>
- $\rho_2$  = Density of gas or lighter liquid in kg/m<sup>3</sup>
- $L$  = Measuring span in mm

**Example:**

- Measuring span: 1.500 m
- $\rho_1$  = 1000 kg/m<sup>3</sup>
- $\rho_2$  = negligible

## 10 DIMENSIONS

244LD up to PN 250 / Class 1500

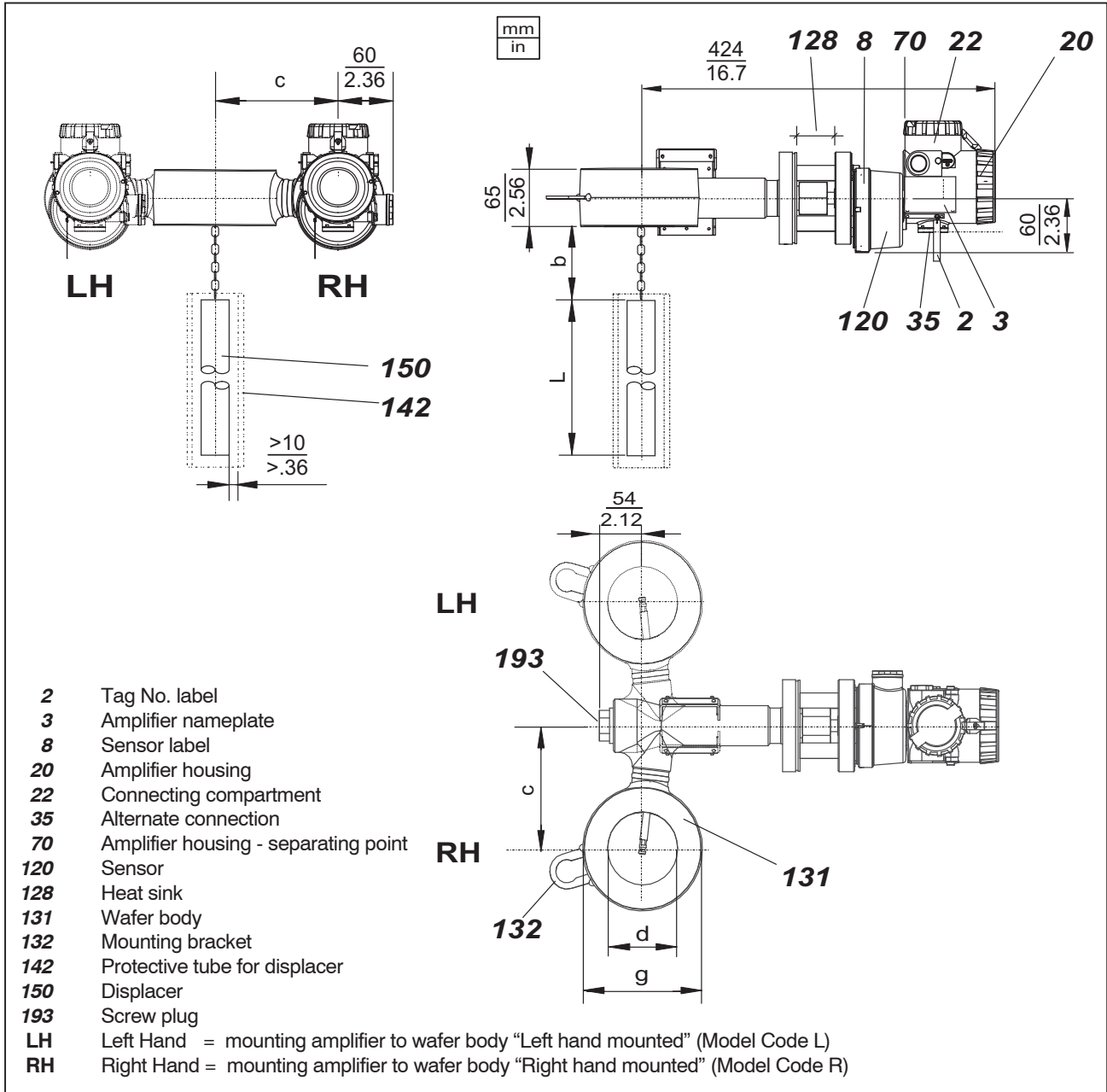

Table of versions

Version		Sealings	DN 80 / 3 inch			DN 100 / 4 inch			
PN			c	d	g	c	d	g	
DIN	16	Form E DIN 2526 Form N DIN 2512	140	82	138	160	102	162	
	40								
	63								
	100								
	160								
	250	Form L DIN 2696							
ANSI	150	Raised Face (RF) ANSI B16.5	140	82	133	160	102	162	
	300				138				
	600				146				
	900	Ring Joint Face (RJF) ANSI B16.5			174				174
	1500								

## 11 SUPPLY OF TRANSMITTER

### 11.1 General

Depending on the transmitter application varying demands are made on the supply. The different operating modes are explained in the following chapters. The wire diagram is shown in Figures 1 to 5.

The power supply units for different applications (direct / via power supply unit of transmitters, HART / FOXCOM / without communication, intrinsically / not intrinsically) are listed in the following table.

All listed supply devices are available for intrinsically-safe and/or non-intrinsically-safe application.

#### Application and associated supply

Application	Supply (recommended)
without communication	direct, <b>MT228</b>
HART	direct, <b>MT228</b>
FOXCOM analog	direct, <b>MT228</b>
FOXCOM digital	Foxboro I/A-System, <b>MT228</b>

### 11.2 Overview of application types

#### Supply via power supply unit (Fig. 1)

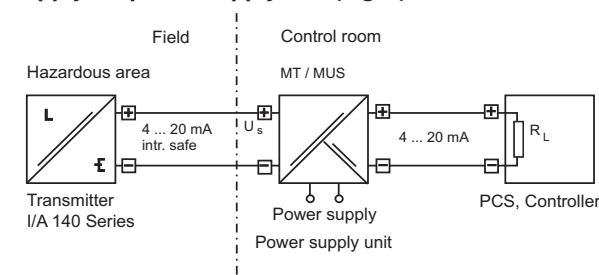

#### Direct supply (Fig. 2)

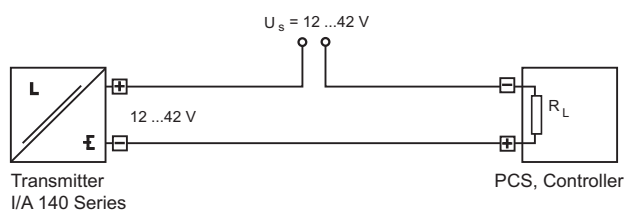

#### Supply via power supply unit with communication (Fig. 3)

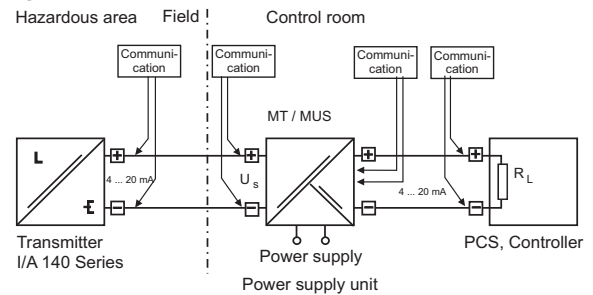

#### Direct supply with communication (Fig. 4)

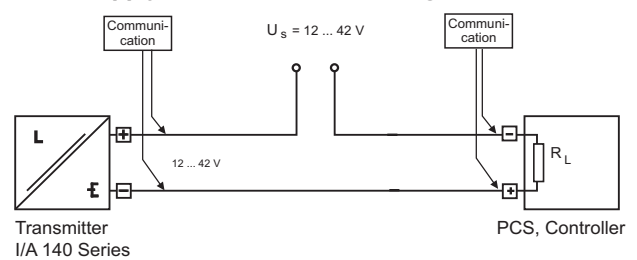

#### Direct supply via Foxboro I/A control system (Fig. 5, FoxCom)

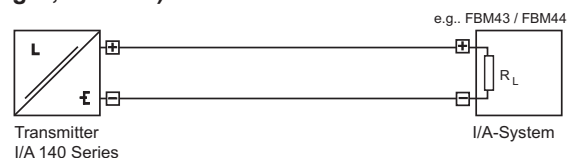

#### 11.2.1 Supply via power supply unit

This supply is recommend for normal use. Interferences are prevented due galvanic separation of measurement loop, load and power supply in the power supply unit (see fig. 1)

#### 11.2.2 Direct supply

This most simple version can be recommended only for single galvanically separated supply or measurement loops (see fig. 2)

The max. load impedance is calculated per:

$$R_{Bmax} = (U_{max} - 12 V) / I_{max}$$

$U_{max}$ : max. permitted voltage (acc. to product specifications), depends on type of transmitter and explosion protection

$I_{max}$ : 12 mA for transmitter in FOXCOM digital mode, 23 mA for all other transmitters (HART and FOXCOM)

**Permissible load depending on supply voltage.**

Example of a non intrinsically safe 140 series HART transmitter (Fig. 6)

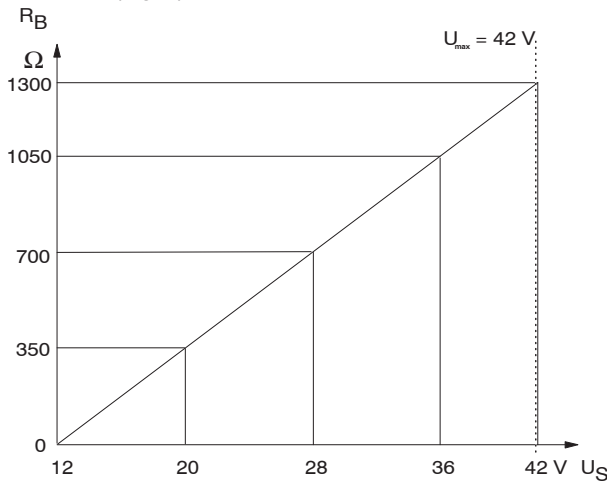

**11.2.3 Communication**

In contrast to conventional operating mode in the two-wire loop a **minimal load for all communication modes** has to be available. If this load is selected too low, the communication is short-circuited.

(FOXBORO power supply units capable for communication (MT228, MUS925) already have respective loads).

Additionally, the line lengths have to be limited to the max. permitted values for the respective communication

Standard values

Communication	HART	FOXCOM analog	FOXCOM digital
Min. load	250 Ω	200 Ω	200 Ω
Max. capacity of line	< 200 nF		
Max. length of line	ca. 3300 m	1800 m	600 m

The respective wiring diagram is shown in Figure 3.

Figure 4 shows the respective wiring diagram without power supply unit for galvanically separated loops. The operating tool - handterminal, PC with software <sup>1)</sup> and modem <sup>2)</sup> - can be connected to the labeled positions. Depending on the application the regulations for explosion protection have to be observed also for the operating tools!

**11.2.4 Intrinsically-safe application**

For intrinsically-safe application generally the use of a respective power supply unit is recommended. Wiring should be done as per respective national and international standards and regulations - as described in "Supply via power supply unit". If communication is required also, the guidelines of chapter "Communication" have to be observed. In addition, the application of the operating tools and their permitted limit values are to be observed.

1) Depending on the communication protocol (HART or FOXCOM) different software tools can be used.  
 HART: PC20, ABO991, TSP991 or WPP991  
 FOXCOM: PC20, PC10  
 For further informations see respective documentation  
 2) Both communication protocols need different modems

### 11.3 PROFIBUS-PA

The operation of the transmitter takes place digital, as per PROFIBUS-PA Profile Class B acc. to EN 50170 and DIN 19245 part 4.

Data transmission via bit synchronous current modulation with a speed of 31250 bits via twisted and shielded two-wire connections acc. to IEC 1158-2.

The transmitter has to be connected to a segment coupler, which has to be conforming to IEC 1158-2. For operation in explosion hazardous areas, a segment coupler in explosion proof version has to be used.

Supply as well as communication takes place via the bus with cable shielded on both sides and bus terminators according to recommendation IEC 1158-2. See also connection in chapter 5.

All components which are connected to the transmitter in an explosion hazardous area, require an Ex Approval. The therein applicable limit values must not be exceeded in any case. These limit values also have to be adhered to when connecting additional capacitances, inductances, voltages and currents.

### 11.4 FOUNDATION Fieldbus

The operation of the transmitter takes place digital, as per Fieldbus Interface acc. to IEC 1158-2, FF Specifications Rev. 1.4, Link-Master (LAS).

Data transmission via bit synchronous current modulation with a speed of 31250 bits via twisted and shielded two-wire connections acc. to IEC 1158-2.

The transmitter has to be connected to a segment coupler, which has to be conforming to IEC 1158-2. For operation in explosion hazardous areas, a segment coupler in explosion proof version has to be used.

Supply as well as communication takes place via the bus with cable shielded on both sides and bus terminators according to recommendation IEC 1158-2. See also connection in chapter 5.

All components which are connected to the transmitter in an explosion hazardous area, require an Ex Approval. The therein applicable limit values must not be exceeded in any case. These limit values also have to be adhered to when connecting additional capacitances, inductances, voltages and currents.

Invensys Systems, Inc.  
38 Neponset Street  
Foxboro, MA 02035  
United States of America

[schneider-electric.com](http://schneider-electric.com)

Global Customer Support  
Toll free: 1-866-746-6477  
Global: 1-508-549-2424  
Website: <http://support.ips.invensys.com>

Copyright 2010-2016 Invensys Systems, Inc.  
All rights reserved.

Invensys, Foxboro, and I/A Series are trademarks  
of Invensys Limited, its subsidiaries, and affiliates.  
All other trademarks are the property of their  
respective owners.

DOKT 556 588 171  
FD-MI-L-001-EN