

Instruction

MI 611-214
February 2016

**PH12 Series pH and ORP Sensors and Accessories
Installation, Troubleshooting, and Maintenance**

Foxboro[®]
by Schneider Electric

Contents

Figures	5
Tables	7
1. Introduction	9
Dangers, Warnings, and Cautions	9
Reference Documents	10
Theory of Operation	10
Standard Specifications.....	11
Sensor Identification	16
2. Installation	17
Removing the Sensor Protection Container	17
General Installation Guidelines	17
NPT Installation	18
Without Sensor Holder	18
With Sensor Holder	18
With Sensor Holder and Standard User-Supplied Tees and Bushings	19
Flange Installation	20
Without Sensor Holder	20
With Sensor Holder	21
Pipe Adapter Installation	21
With Sensor Holder and Standard User-Supplied Tees and Bushings.....	22
3-A Compliant Connections	23
Tri-Clamp Type 3-A Compliant Sanitary Connection Installation	23
DN25 Threaded 3-A Compliant Sanitary Installation	23
Flow Chamber	24
Installation Using the Retraction/Insertion Assembly	25
Initial Installation	25
Removal and Installation of a Sensor	26
Installation Using the Ball Valve Insertion Assembly (BVA Series)	27
Installing the Ball Valve Assembly into the Process - Model BVA-PHD	27
Installing the Sensor into the Insertion Tube Assembly	28
Installing the Insertion Tube into a Ball Valve.....	29
Removing and Replacing the Sensor	30
Replacing O-Ring Seals and the Split Washer in the Ferrule Seat.....	31

Wiring	31
Cable Variations	31
Cable Length.....	32
Connections to Analyzer or Transmitter	32
Variopin Connectors	33
3. Troubleshooting	35
4. Maintenance.....	37
Calibration.....	37
Temperature Calibration	37
Electrode Inspection.....	37
Electrode Cleaning.....	38
Cleaning a Glass Electrode	38
Cleaning an ORP Electrode	38
Cleaning the Reference Junction.....	38
Sanitizing the Sensor	39
Storing a Sensor	39

Figures

1	Sensor Parts (pH sensor shown)	12
2	Sample Sensor Identification	16
3	3-A 74-xx Compliant Sensor	16
4	NPT Installation Without Sensor Holder.....	18
5	NPT Installation With Sensor Holder.....	18
6	NPT Installation With Sensor Holder and Standard User-Supplied Tees and Bushings	19
7	Flange Installation Without Sensor Holder	20
8	Flange Installation With Sensor Holder.....	21
9	Pipe Adapter Installation for Submersion/Immersion Applications for 120 mm sensors only	21
10	Pipe Adapter Used for NPT Installations.....	22
11	Pipe Adapter Installation With Sensor Holder and Standard User-Supplied Tees and Bushings	22
12	Tri-Clamp Type 3-A Compliant Sanitary Installation	23
13	DN25 Threaded 3-A Compliant Sanitary Installation.....	23
14	Flow Chamber	24
15	Retraction/Insertion Assembly	26
16	Ball Valve Assembly	27
17	Retraction Chamber	27
18	Insertion Tube Assembly	27
19	Installing PH12 Sensor into Guarded Sensor Holder	28
20	Installing Sensor into the Insertion Tube Assembly	28
21	Installing Insertion Tube into Ball Valve	29
22	Removing and Replacing the Sensor	30
23	Replacing O-Ring Seals and Split Washer in the Ferrule Seat	31
24	Cable Length.....	32

Tables

1	Temperature-Pressure Ratings of Flange, NPT, and NPT Pipe Adapter Accessories with 316L ss Material.....	14
2	Temperature-Pressure Ratings of Flange, NPT, NPT Pipe Adapter Accessories, and Retraction/Insertion Assembly with CPVC or Kynar Material.....	14
3	Temperature-Pressure Ratings of Retraction/Insertion Assembly and Ball Valve Insertion Assembly with 316L ss and Titanium Material.....	15
4	Flow Chamber Specifications	24
5	Retraction/Insertion Assembly Specifications	25
6	Analyzer and Transmitter Connections.....	32
7	Standard Temperature Cable Wiring	32
8	High Temperature Cable Wiring.....	33
9	Process Temperature vs. RTD Resistance.....	35
10	Sensor Troubleshooting	36

1. Introduction

The PH12 Series pH and ORP Sensors are suitable for a wide range of pH and ORP measurement applications. They are designed for use with Foxboro 875PH, 873PH, and 873DPX Analyzers and 876PH and 870ITPH Transmitters. Some can also be used with 873APH Analyzers and analyzers of other companies. When used with an 875PH, 876PH, or 870ITPH, they provide the additional capability of on-line diagnostics to signal the user if any of several common sensor faults occur.

The sensors are available with a choice of temperature compensation, process seal materials, and electrode configurations. The sensors can be mounted to the process in a number of ways. They have a PG13.5 external connection integral to the sensor which allows the sensor to be mated to a variety of accessories including bushings, flanges, flowchambers, Retraction/Insertion and Ball Valve Insertion assemblies.

Dangers, Warnings, and Cautions

DANGER

When installing or removing sensors, wear appropriate protective clothing including safety goggles. Escaping chemicals under pressure can cause severe injury, including blindness.

WARNING

1. Use care when connecting and disconnecting high-pressure service connection. Use proper gloves and follow the recommended procedures to avoid severe injury to personnel or damage to equipment.
 2. When processing hazardous liquids, follow the recommended procedures. Failure to do so could result in injury to personnel and damage to equipment.
 3. Use only Foxboro replacement parts. Substitution parts could result in damage to equipment, damage to the process, and/or injury to personnel.
(Avoid exposing sensor for prolonged periods to dry atmospheres at elevated temperatures, as sensor lifetime may be reduced.)
 4. In addition to the pressure and temperature limits of the sensor, the PH12 mounting accessories also have pressure and temperature limits. The specifications for the mounting accessories may be greater or less than the sensor specifications. Always use the lesser of the two specification limits when designing the installation of PH12 sensors with accessories.
 5. Due to differing thermal expansion coefficients, take care to match the material of piping and fitting to the mounting accessories.
-

CAUTION

To prevent damage, use care when handling sensitive sensor components such as glass electrodes.

Reference Documents

Document No.	Description
DP 611-174	Junction Box BS813XN
DP 611-160	Junction Box BS807BZ
DP 611-174	Remote Preamplifier Junction Box BS811MR
DP 611-214	PH12 Series pH Sensors and Accessories
MI 611-165	873PH Series Electrochemical Analyzers for pH or ORP Measurement
MI 611-190	873DPX Dual pH, ORP, or ISE Electrochemical Analyzers
MI 611-191	873APH Ace Series Electrochemical Analyzers for pH Measurement
MI 611-211	870ITPH Transmitters for pH, ORP, and ISE Measurements
MI 611-215	PH12 Series pH and ORP Sensors
MI 611-225	875PH Analyzers for pH, ORP, and ISE Measurements
MI 611-262	876PH Transmitters for pH, ORP, and ISE Measurements
PL 611-214	PH12 Series PH Sensors and Accessories

Theory of Operation

pH indicates the concentration of hydrogen ions (H^+) present in aqueous solution. Since the concentration of hydrogen ions determines the degree of acidity or alkalinity of the solution, pH is also said to be a measure of acidity or alkalinity. pH is defined as the negative logarithm of the hydrogen ion concentration:

$$pH = -\log [H^+]$$

The pH scale ranges from 0 to 14 with a pH of 7 being neutral, a pH less than 7 being acidic, and a pH greater than 7 being basic (alkaline).

Measurement of pH using a PH12 series pH sensor is accomplished by immersing the sensing tip of the probe, which consists of integral pH and reference electrodes, in the process solution. The pH electrode, which is sensitive to hydrogen ions in solution, develops an electrical potential proportional to pH. The reference electrode, which consists of Silver/Silver Chloride connected to the process via a Potassium Chloride salt bridge through a ceramic junction, provides a stable reference potential against which the glass electrode potential is measured. These two electrodes constitute a galvanic cell having a millivolt output proportional to the pH of the solution.

PH12 sensors are well suited for a wide variety of applications. Multiple electrode choices are offered for low and high temperature applications. The PH12 sensors comply with 3-A Standard 74-xx and FDA requirements for elastomers, so they can be used successfully in the dairy and food processing industries. In addition, the PH12 sensors are certified to be biocompatible according to United States Pharmacopeia & National Formulary (USP 87) and ANSI/AAMI/ISO 10993-5 criteria; the sensors perform well in challenging applications found in biopharmaceutical processes, and can withstand multiple cycles of sterilization.

Standard Specifications

Measurement Range:

Domed Glass Electrode: 0 to 14 pH

Flat Ruggedized Glass Electrode: 0 to 12 pH

Platinum Electrode: The measurement range (mV) is limited only by the readout instrument

Automatic Temperature Compensation (ATC):

Integral temperature element provides temperature measurement for pH compensation over the full rated temperature range of the pH sensor. The integral temperature elements are:

- ◆ 100 Ω Platinum RTD or
- ◆ 1000 Ω Platinum RTD

— NOTE

Both RTDs are 3-wire type to provide lead length compensation. They can be used with analyzers and transmitters that accept either 2- or 3-wire temperature elements. Refer to Table 9 for resistance temperature relationships.

Storage Temperature Limits: -5 and +65°C (23 and 149°F)

Process Pressure Normal Operating Conditions: -48 and +1034 kPa (-7 and +150 psig)

Process Temperature Normal Operating Conditions:

Domed Glass (Wide Temp) pH: -25 and +125°C (-13 and +257°F)

Domed Glass (High Temp) pH: 0 and 140°C (32 and 284°F)

Flat Ruggedized Glass pH: -15 and +125°C (5 and 257°F)

Platinum (ORP): -25 and +125°C (-13 and +257°F)

— NOTE

Use pH temperature values for combination pH and platinum electrodes. High temperature limits are valid for intermittent service such as sterilization in a bioreactor. Continuous operation at the maximum temperatures, especially in aggressive solutions, may reduce sensor lifetime.

Sensor Materials:

Sensor Body: PEEK or Borosilicate Glass as specified

Measuring Electrode:

- ◆ pH Measurement: Domed or flat glass.
- ◆ ORP Measurement: Platinum

Internal electrode is silver wire coated with silver chloride.

Sensor Length: 120 mm (4.7 in), 225mm (8.9 in), 360 (14.2 in), and 425 mm (16.7 in)

Reference Electrode: Internal electrode is silver wire coated with silver chloride (inside a Nafion ion barrier).

Reference Junction: Ceramic

Solution Ground:

- ◆ pH or ORP Measurement: Conductive Kynar (nonmetallic), or stainless steel (option -S).
- ◆ pH/ORP Combination Measurement: Platinum

Process O-Ring and Electrode Seal: Viton is standard; EPDM and Perfluoroelastomer (FFKM) are optional.

Reference Electrolyte: Gelled electrolyte

Process Connector: Valox

Thrust Washer: Glass filled (25%) PTFE

Figure 1. Sensor Parts (pH sensor shown)

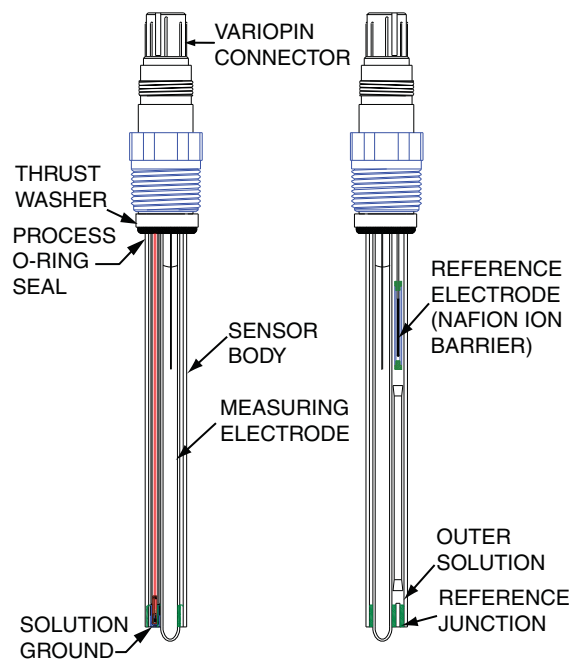

Variopin Connector Protection Class: Meets the ingress protection of IP66/68 per IEC 60529. IP68 immersion is at a depth of 2 m (6.6 ft) for 48 hours.

Sensor Mounting: Up to 90° from vertical with the electrode end downward.

Electromagnetic Compatibility (EMC):

When properly installed per the applicable installation instructions with Foxboro Models 870ITPH and 876PH Transmitters, 875PH Analyzers, applicable Models 873, or other compliant transmitters or analyzers, the PH12 Series sensors comply with the electromagnetic compatibility requirements of European EMC Directive 2004/108/EC by conforming to the following EN and IEC Standards: EN-61326-1, and IEC 61000-4-2 through 61000-4-6.

Electrical Safety Specifications:

The PH12 Sensor meets the requirements of a simple apparatus as defined below.

An electrical component or combination of components of simple construction with well-defined electrical parameters which does not generate more than 1.5 V, 100 mA, and 25 mW or a passive component which does not dissipate more than 1.3 W. Certification to the ATEX directive is not required because of the low levels of energy which are added to the intrinsically safe circuit by this apparatus. When connected to an intrinsically safe pH/ORP transmitter, such as a Foxboro Model 870ITPH or 876PH, the PH12 sensor can be installed in a Division 1 or Zone 0 hazardous area.

The following are examples of a simple apparatus:

- a. Passive components, for example, switches, junction boxes, resistance temperature devices, and simple semiconductor devices such as LEDs.
- b. Sources of generated energy, for example, thermocouples and photocells, which do not generate more than 1.5 V, 100 mA and 25 mW.

Accessory Materials:

Holder or Process Connection: 316L ss, CPVC, or Kynar.

Holder O-Ring: Viton, EPDM, Chemraz, Kalrez, or Perfluoroelastomer (FFKM).

Accessory Temperature-Pressure Ratings:

Table 1 shows the ratings of the flange, NPT, and NPT pipe adapter accessories with 316L ss material.

Table 2 shows the ratings of the flange, NPT, and NPT pipe adapter accessories with CPVC and Kynar material.

For Retraction/Insertion assemblies, use 316L ss flange ratings in Table 1.

For Ball Valve Insertion assemblies, use the ratings of the Retraction/Insertion Assembly and Ball Valve Insertion assembly accessories with 316L ss and Titanium material as given in Table 3.

For the DN 25 threaded sanitary connection and the Tri-clamp type sanitary connection accessories, refer to the vendor's literature for temperature-pressure ratings. Use the sensor's rating or the vendor's rating, whichever is less.

Table 1. Temperature-Pressure Ratings of Flange, NPT, and NPT Pipe Adapter Accessories with 316L ss Material

Process Temperature		Maximum Working Pressure of Flange, NPT, or NPT Pipe Adapter Accessory			
		316L ss Flange (a)		316L ss, 3/4 and 1 NPT or NPT Pipe Adapter (b)	
°C	°F	MPa	psi	MPa	psi
-29	-20	1.59	230	20.7	3000
-18	0	1.59	230	20.7	3000
10	50	1.59	230	20.7	3000
38	100	1.59	230	20.7	3000
66	150	1.59	230	20.7	3000
93	200	1.35	195	20.7	3000
121	250	1.28	185	20.7	3000
149	300	1.21	175	20.7	3000

- a. Flange applies to Process Connection Accessory Code F* (ANSI Class 150 Flange).
- b. NPT applies to Process Connection Accessory Code N* (NPT), and NPT Pipe Adapter applies to Process Connection Code S* (NPT Pipe Adapter).

— NOTE —

The ratings in the table above may exceed the rating of the sensor itself. However, use the above ratings or sensor rating, whichever is less.

Table 2. Temperature-Pressure Ratings of Flange, NPT, NPT Pipe Adapter Accessories, and Retraction/Insertion Assembly with CPVC or Kynar Material

Process Temperature		Maximum Working Pressure of Flange, NPT, or NPT Pipe Adapter Accessory											
		CPVC Material						Kynar Material					
		Flange (a)		3/4 NPT (b)		1 NPT (b)		Flange		3/4 NPT (b)		1 NPT (b)	
°C	°F	kPa	psi	kPa	psi	kPa	psi	kPa	psi	kPa	psi	kPa	psi
-30	-22	1034	150	2344	340	2206	320	1034	150	1586	230	1448	210
-25	-13	1034	150	2344	340	2206	320	1034	150	1586	230	1448	210
-15	5	1034	150	2344	340	2206	320	1034	150	1586	230	1448	210
-10	14	1034	150	2344	340	2206	320	1034	150	1586	230	1448	210
0	32	1034	150	2344	340	2206	320	1034	150	1586	230	1448	210
10	50	1034	150	2344	340	2206	320	1034	150	1586	230	1448	210
21	70	1034	150	2344	340	2206	320	1034	150	1586	230	1448	210
27	80	993	144	2277	326	2117	307	979	143	1510	219	1379	200
32	90	952	138	2158	313	2027	294	903	131	1379	200	1262	183
38	100	883	128	1993	289	1875	272	827	120	1269	184	1158	168
43	110	800	116	1806	262	1696	246	779	113	1193	173	1089	158
46	115	765	111	1738	252	1634	237	738	107	1124	163	1027	149
49	120	724	105	1641	238	1544	224	703	102	1076	156	979	143
52	125	683	99	1544	224	1455	211	683	99	1048	152	958	139
54	130	641	93	1455	211	1365	198	641	93	979	143	896	130
60	140	572	83	1289	187	1214	176	600	87	917	133	841	122

Table 2. Temperature-Pressure Ratings of Flange, NPT, NPT Pipe Adapter Accessories, and Retraction/Insertion Assembly with CPVC or Kynar Material

Process Temperature		Maximum Working Pressure of Flange, NPT, or NPT Pipe Adapter Accessory											
		CPVC Material						Kynar Material					
		Flange (a)		3/4 NPT (b)		1 NPT (b)		Flange		3/4 NPT (b)		1 NPT (b)	
°C	°F	kPa	psi	kPa	psi	kPa	psi	kPa	psi	kPa	psi	kPa	psi
66	150	490	71	1103	160	1034	150	538	78	827	120	752	109
71	160	414	60	938	136	883	128	510	74	779	113	703	103
77	170	331	48	752	109	703	102	469	68	717	104	655	95
82	180	262	38	586	85	552	80	434	63	669	97	607	88
93	200	186	27	421	61	400	58	372	54	572	83	524	76
99	210	159	23	352	51	331	48	345	50	524	76	476	69
116	240		–		–		–	262	38	400	58	365	53
121	250		–		–		–		–		–		–

a. Flange applies to Process Connection Accessory Code F* (ANSI Class 150 Flange).

b. NPT applies to both the Process Connection Accessory Code N* (NPT) and Process Connection Accessory Code S* (NPT Pipe Adapter).

NOTE

The ratings in the table above may exceed the rating of the sensor itself. However, use the above ratings or sensor rating, whichever is less.

CAUTION

Pressure spikes/surges, water hammer, and impact should be avoided since these effects can be detrimental as the plastic becomes brittle at temperatures below -18°C (0°F).

Table 3. Temperature-Pressure Ratings of Retraction/Insertion Assembly and Ball Valve Insertion Assembly with 316L ss and Titanium Material

Process Temperature		Maximum Working Pressure of Retraction/Insertion Assembly and Ball Valve Insertion Assembly			
		with 316L ss Material		with Titanium Material	
°C	°F	MPa	psi	MPa	psi
-29 to +66	-20 to +150	1.59	230	1.90	275
93	200	1.35	195	1.72	250
121	250	1.28	185	1.62	240
149	300	1.21	175	1.59	230

Sensor Identification

Labels on the PH12 sensor allow easy sensor identification. One is wrapped around the circumference of the sensor above the sensor bushing. It contains the model number, serial number, style letter, and origin code (plant, year and week of manufacture). The second label is affixed along the body of the sensor. It contains the pH range and the allowable temperature range. Another label, shown in Figure 3, is affixed to the sensor if the sensor is 3-A 74-xx compliant.

Figure 2. Sample Sensor Identification

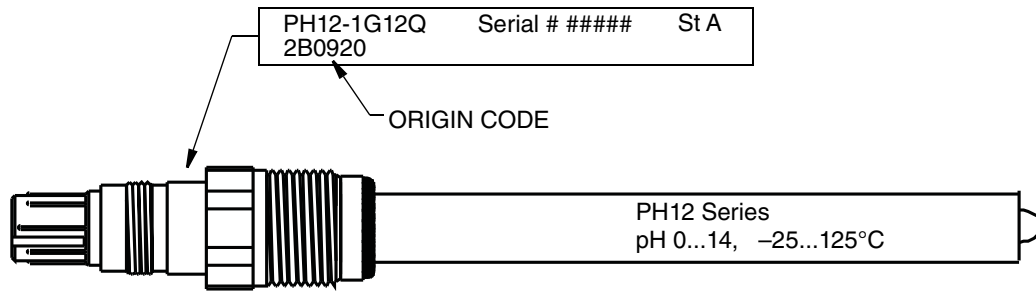

Figure 3. 3-A 74-xx Compliant Sensor



2. Installation

Removing the Sensor Protection Container

Your sensor was shipped with a protection container, containing an electrolyte solution. The container should remain in place until you are ready to install your sensor in the process. To remove the container, first unscrew the bottle portion using care not to splash its liquid contents. Then pull the cap off with a slight twisting motion. Save the container for storing the sensor properly when not in use. See “Storing a Sensor” on page 39.

General Installation Guidelines

— **NOTE** —

All piping techniques should comply with standard and acceptable practices.

Proper mounting of the sensor is important for efficient and accurate operation.

For dimensional information, see Dimensional Prints listed in “Reference Documents” on page 10.

Do **not** wrap PTFE tape on PG13.5 sensor threads.

For all applications and sensor configurations, mounting arrangements must be located so that:

- ◆ Sample at the sensing area is representative of the process solution.
- ◆ Solution circulates actively and continuously past the sensing area (electrodes should stay wetted at all times).
- ◆ Flow velocity at sensing area does not cause cavitation or electrode damage.
- ◆ Position and orientation of the sensor does not trap air bubbles within the sensing area.
- ◆ Orientation of the sensor is any position up to 90° from vertical with the electrode end downward.
- ◆ Accessibility for maintenance and replacement is considered. A flow-type installation must have blocking valves (user supplied) to allow for sensor replacement.
- ◆ Deposits of sediment or other foreign material do not accumulate within the sensing area.
- ◆ Provision for removal of the sensor from the process is considered. If cable is installed in metal conduit (recommended), either use flexible conduit or make some other provision.

⚠ CAUTION

When installing a sensor, be careful **not** to bottom the sensor in the vessel, particularly in a small diameter pipe.

NPT Installation

The sensor can be mounted using the 3/4 NPT or 1 NPT mounting accessory. Two options are available; with and without a sensor holder.

Without Sensor Holder

1. Wrap PTFE tape on the external threads of the NPT bushing and thread the bushing into the process vessel. Tighten as required.
2. Thread the sensor into the bushing. Tighten as required.

Figure 4. NPT Installation Without Sensor Holder

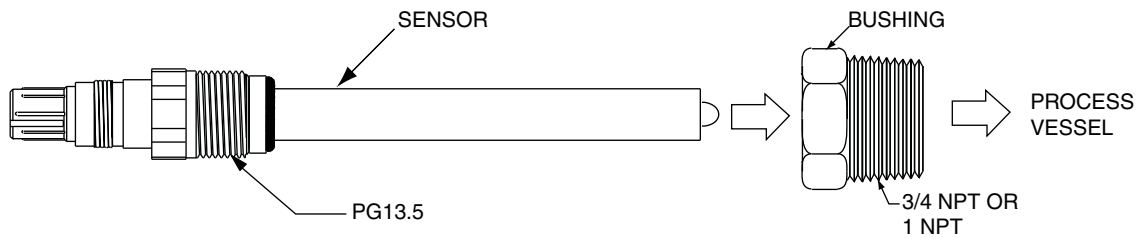

With Sensor Holder

1. Wrap PTFE tape on the external NPT threads of the holder and thread the holder into the process vessel. Tighten as required.
2. Thread the sensor into the holder. Tighten as required.

Figure 5. NPT Installation With Sensor Holder

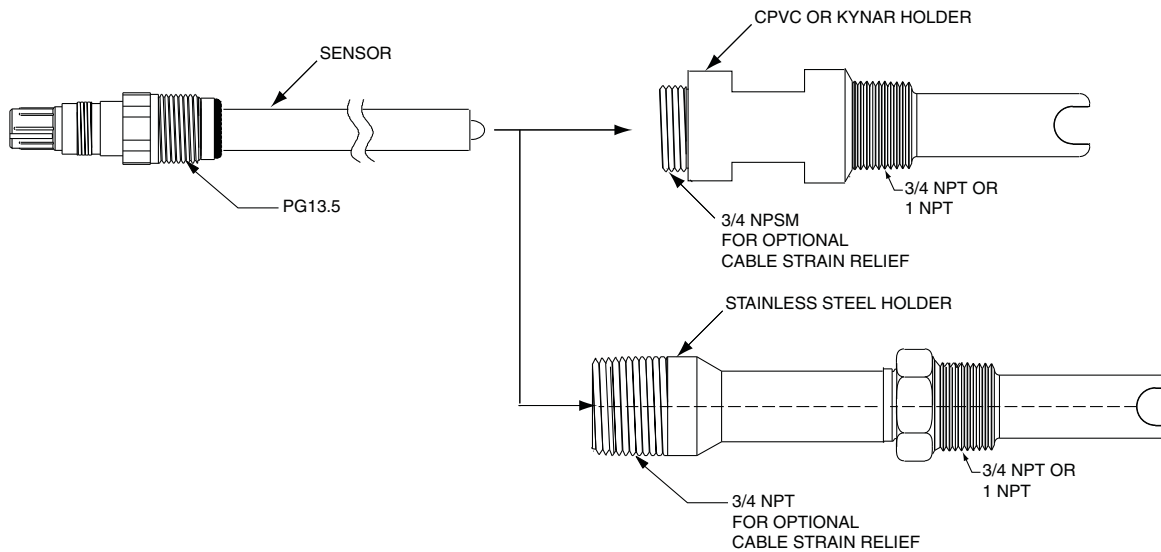

With Sensor Holder and Standard User-Supplied Tees and Bushings

Figure 6. NPT Installation With Sensor Holder and Standard User-Supplied Tees and Bushings

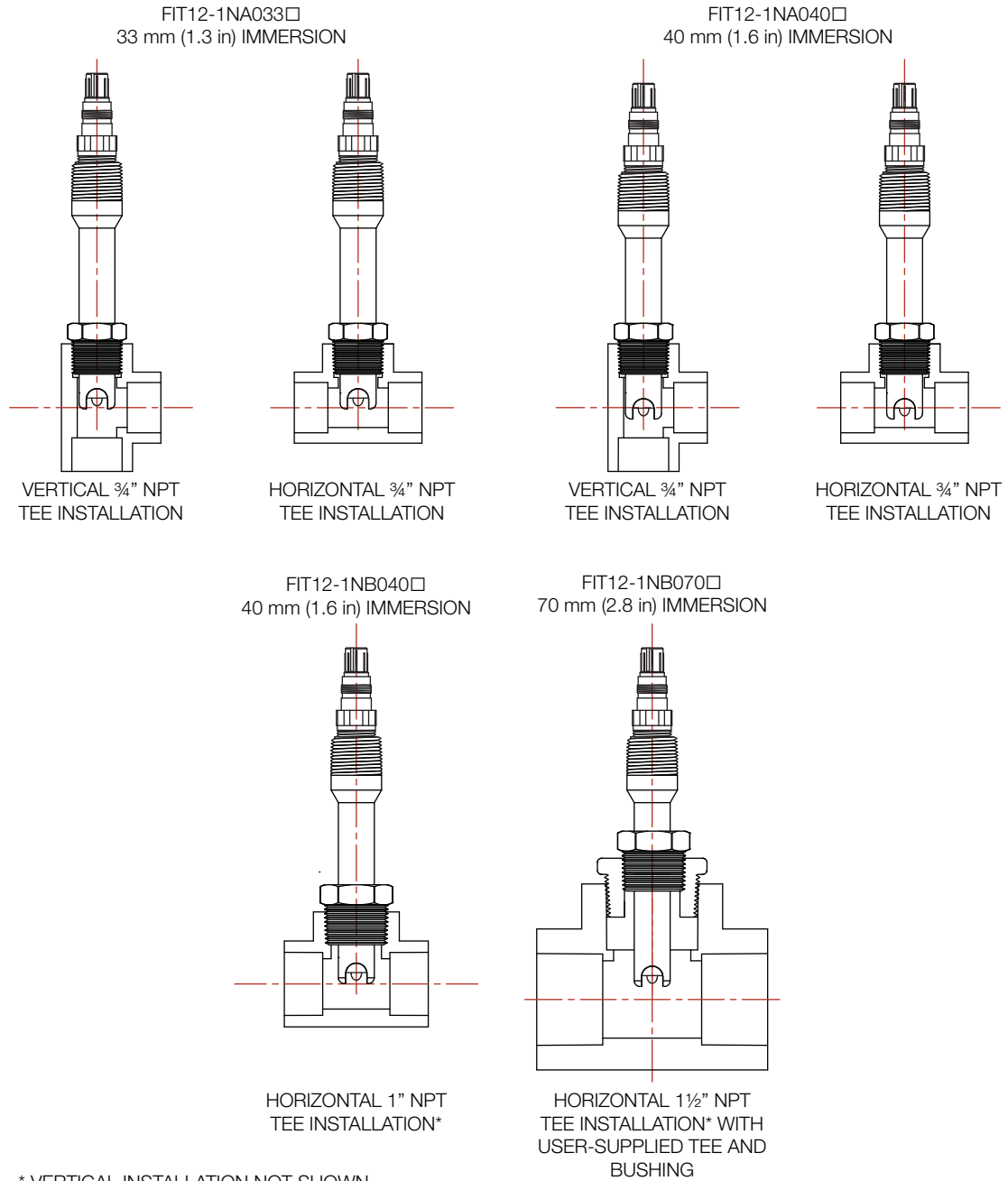

Flange Installation

The sensor can be mounted using the 3/4-, 1-, 1 1/2-, or 2-inch ANSI Class 150 flange connection mounting assembly. Two options are available; with and without a sensor holder.

Without Sensor Holder

1. Mount the flange to the process vessel.
2. Thread the sensor into the flange. Tighten as required.

Figure 7. Flange Installation Without Sensor Holder

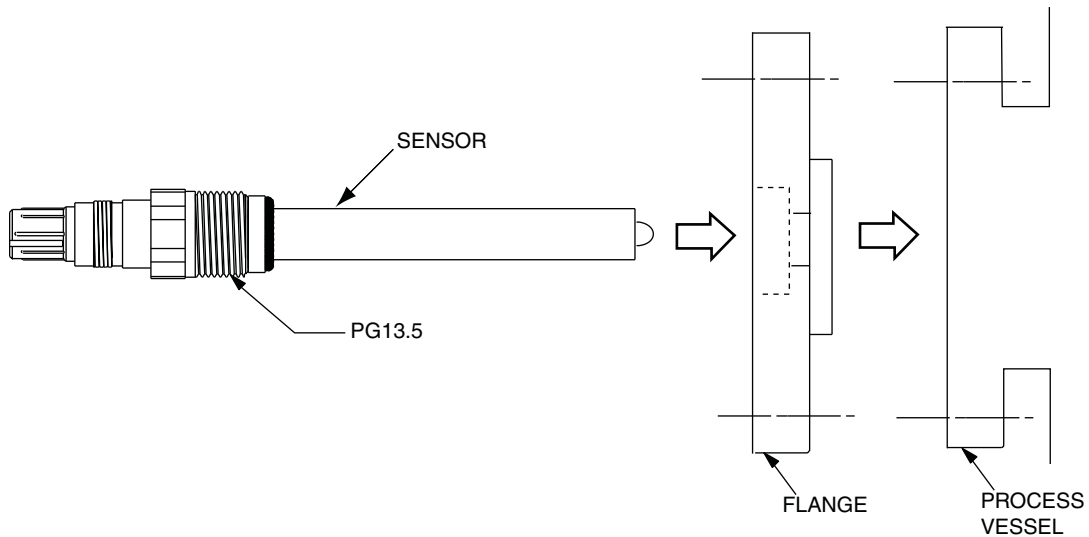

With Sensor Holder

1. Mount the flange (containing the sensor holder) to the process vessel.
2. Thread the sensor into the sensor holder. Tighten as required.

Figure 8. Flange Installation With Sensor Holder

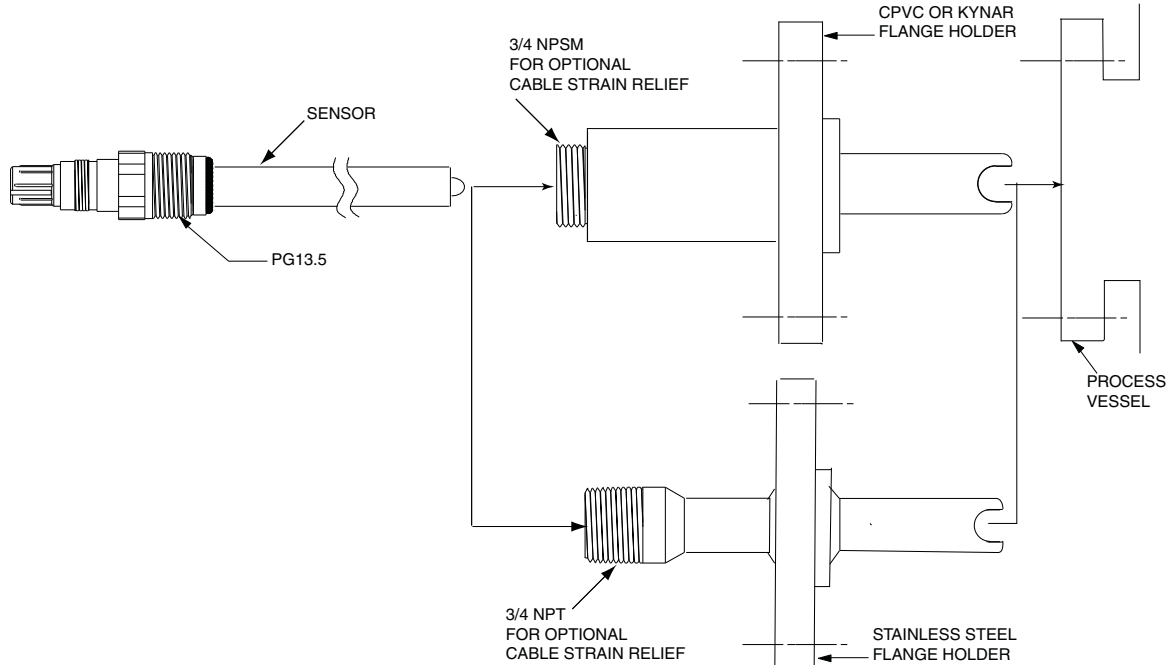

Pipe Adapter Installation

The pipe adapter mounting assembly can be used in two ways. It is primarily used for submersion/immersion applications. To use it in this type of application:

1. Thread the sensor into the pipe adapter. Tighten as required.
2. Wrap PTFE tape on the top external NPT threads of the pipe holder.
3. Thread the cable through the pipe and connect Variopin quick disconnect to sensor.
4. Fasten the pipe to top end of the adapter. Tighten as required.

Figure 9. Pipe Adapter Installation for Submersion/Immersion Applications for 120 mm sensors only

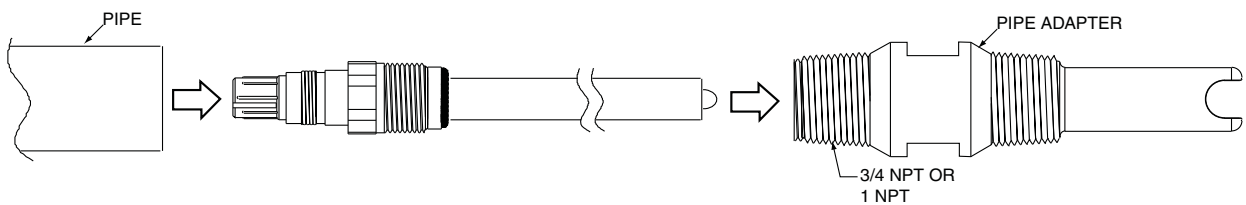

The pipe adapter mounting assembly can also be used as a 3/4 NPT or 1 NPT mounting accessory. To use it in this type of application:

1. Wrap PTFE tape on the bottom external NPT threads of the pipe adapter and thread the adapter into the process vessel. Tighten as required.
2. Thread the sensor into the pipe adapter. Tighten as required.

Figure 10. Pipe Adapter Used for NPT Installations

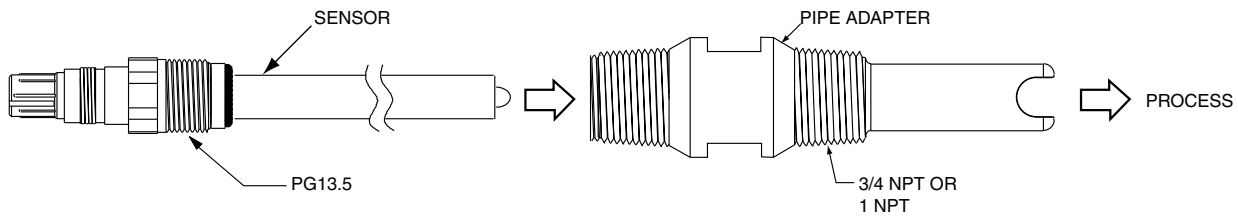

With Sensor Holder and Standard User-Supplied Tees and Bushings

Figure 11. Pipe Adapter Installation With Sensor Holder and Standard User-Supplied Tees and Bushings

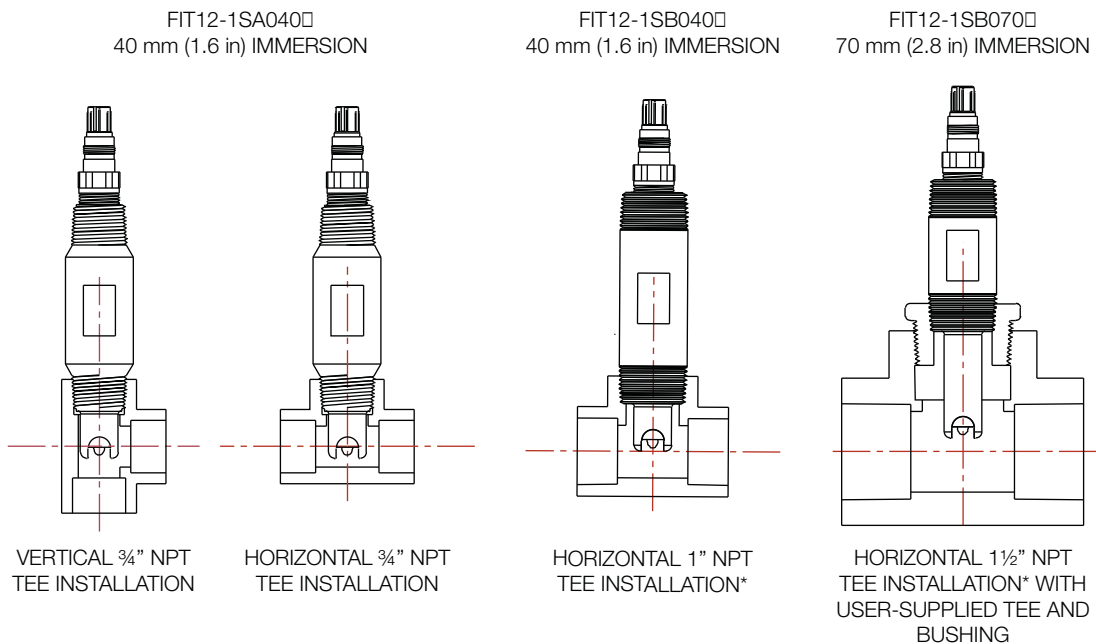

* VERTICAL INSTALLATION NOT SHOWN

3-A Compliant Connections

Tri-Clamp Type 3-A Compliant Sanitary Connection Installation

The sensor can be mounted for sanitary applications using a Tri-Clamp type connection mounting assembly.

1. Thread the sensor into the sensor holder. Tighten as required.
2. Mount the Tri-Clamp type holder to the process vessel. Apply the clamp.

NOTE

For 3-A sanitary compliance, the sensor and holder must be mounted in the horizontal position with the leak detection port pointing down.

Figure 12. Tri-Clamp Type 3-A Compliant Sanitary Installation

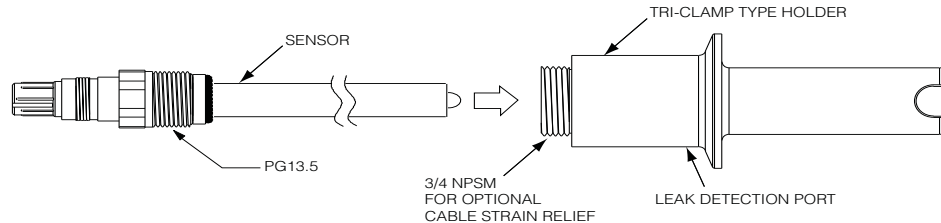

DN25 Threaded 3-A Compliant Sanitary Installation

The sensor can also be mounted for sanitary applications using a threaded connection mounting assembly.

1. Thread the sensor into the sensor holder. Tighten as required.
2. Mount the holder to the process vessel. Tighten the threaded clamp.

Figure 13. DN25 Threaded 3-A Compliant Sanitary Installation

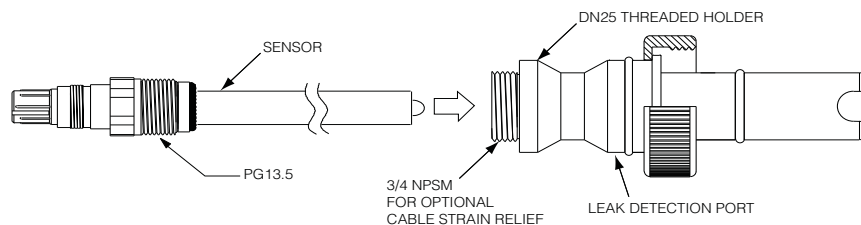

NOTE

All 3-A compliant mountings are described on this page.

Flow Chamber

Flow chambers are a convenient way of mounting 120 mm (4.7 in) sensors in a system where a sample is provided by a small diameter sample line. The inlet and outlet ports of the flow chamber have 1/2 NPT internal threads and connect to the system with user-supplied fittings. The sensor connection is PG 13.5. See Table 4 for flow chamber Pressure and Temperature Ratings.

The flow chambers are designed to be used with 120 mm (4.7 in) PH12 sensors.

Table 4. Flow Chamber Specifications

Flow Chamber Material	Part Number	Maximum Pressure/Temperature Rating
316L ss	BS813LA	1.4 MPa at 140°C (200 psi at 284°F)
Kynar	BS813LB	0.7 MPa at 90°C (100 psi at 194°F) 0.35 MPa at 125°C (50 psi at 257°F)
CPVC	BS813LC	0.7 MPa at 70°C (100 psi at 158°F) 0.4 MPa at 85°C (60 psi at 185°F)

CAUTION

The flow chamber can pass up to 125 mL/s (2 gpm) of process sample without introducing a damagingly high pressure drop. To avoid damage to the sensor, do not exceed 125 mL/s (2 gpm).

Figure 14. Flow Chamber

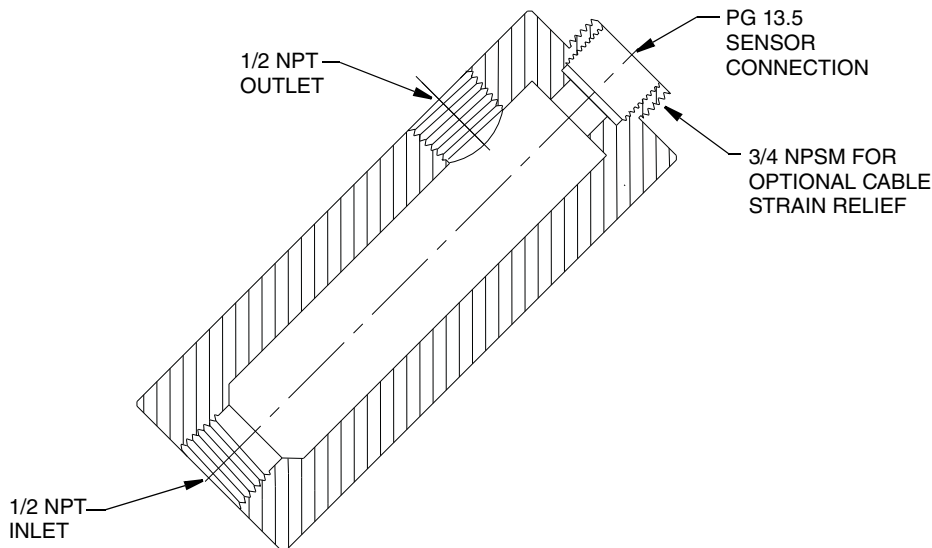

A flow chamber installation must meet mounting arrangements specified in “General Installation Guidelines” on page 17 as well as the following requirements:

- ◆ Mount the flow chamber so that the sensor is located between vertical and 45° with the electrodes facing down.
- ◆ Direct the outlet piping **upward** a minimum of 50 mm (2 in) so that bubbles do not settle on the measuring electrode.
- ◆ Provide space for removal of the sensor from the flow chamber.

Installation Using the Retraction/Insertion Assembly

A Retraction/Insertion assembly is used for two purposes. First, it allows insertion of a PH12 sensor into the process at the required depth. Second, it permits a PH12 sensor to be inserted and removed from a process stream or tank under rated temperature and pressure without draining the system or resorting to a bypass arrangement.

The Retraction/Insertion assembly is offered in 316L ss, Titanium, CPVC, or Kynar material. Process O-Ring seals (4) are Viton as standard, and optionally EPDM, Chemraz, Kalrez, or perfluoroelastomer (FFKM). Process connections can be either 1, 1 1/4, or 1 1/2 NPT, and the threads for the cable strain relief housing are 3/4 NPSM. An alignment groove is provided to align the sensor into the insertion assembly. The alignment groove provides a visual reference as to the position of the sensor when inserted into the process.

Table 5. Retraction/Insertion Assembly Specifications

Parameter	Specification
Process Connection	1, 1 1/4, or 1 1/2 NPT
O-Ring Material	Viton (standard); EPDM, Chemraz, Kalrez, or perfluoroelastomer (FFKM) (optional)
Retraction/Insertion Assembly Material	316L ss, Titanium, CPVC, or Kynar material
Temperature/Pressure Rating	See Table 2 (316L ss flange ratings) or Table 3 (CPVC or Kynar flange ratings)

Initial Installation

Refer to Figure 15.

1. Wrap PTFE tape on the external NPT threads of the ferrule seat and insert the assembly into the process vessel. Tighten the ferrule seat as required.
2. Remove the cable strain relief from the Retraction/Insertion assembly.
3. Thread the sensor into the Retraction/Insertion assembly. Tighten as required.
4. Thread the cable through the cable strain relief and connect the Variopin quick disconnect to the sensor.
5. Fasten the cable strain relief housing to the Retraction/Insertion assembly. Tighten as required.
6. Tighten the strain relief nut.
7. Grasping large end of FIT shaft and cable strain relief housing, push the shaft to insert the sensor into the process to the desired depth. Retighten the tube nut.

Removal and Installation of a Sensor

Refer to Figure 15.

1. Loosen the tube nut of the Retraction/Insertion assembly.
2. Grasping large end of FIT shaft and cable strain relief housing, pull shaft back as far as you can. Retighten tube nut.
3. Loosen the strain relief nut and remove the cable strain relief housing from the Retraction/Insertion assembly.
4. Disconnect the Variopin quick disconnect from the sensor.

NOTE

Depending on the condition of the O-rings, process seepage is possible as you perform the next step. Take all necessary precautions.

5. Remove the sensor from the Retraction/Insertion assembly. Replace with new sensor.
6. Connect the Variopin quick disconnect to the sensor.
7. Connect the cable strain relief housing to the Retraction/Insertion assembly. Tighten the strain relief nut.
8. Loosen the tube nut.
9. Grasping large end of FIT shaft and cable strain relief housing, push the shaft to insert the sensor into the process to the desired depth. Retighten the tube nut.

Figure 15. Retraction/Insertion Assembly

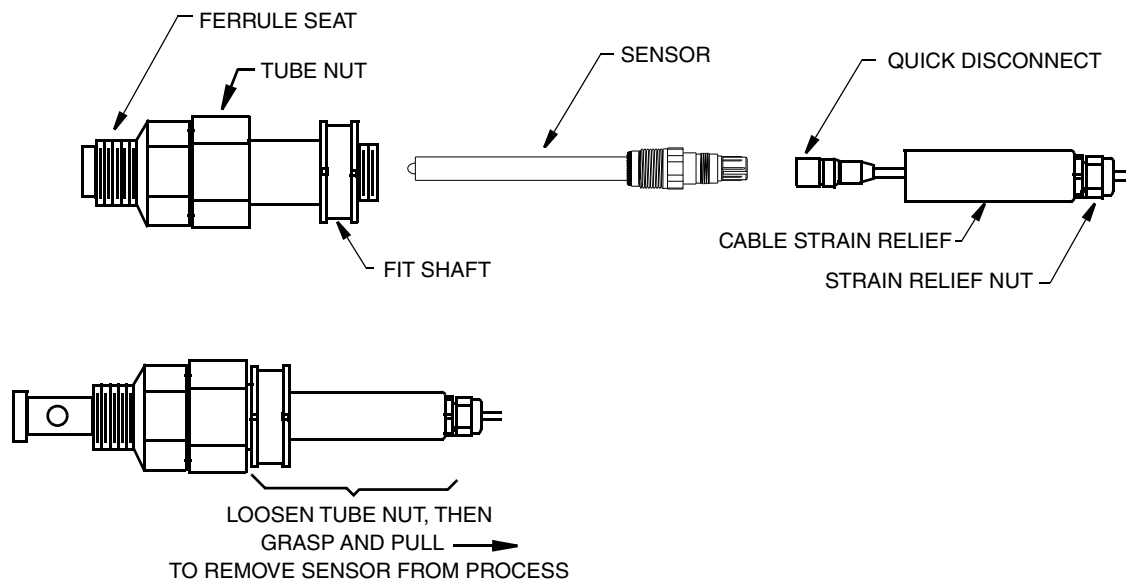

NOTE

An alignment groove is provided to align the sensor into the insertion assembly. The alignment groove provides a visual reference as to the position of the sensor when inserted into the process.

Installation Using the Ball Valve Insertion Assembly (BVA Series)

Installing the Ball Valve Assembly into the Process - Model BVA-PHD

Figure 16. Ball Valve Assembly

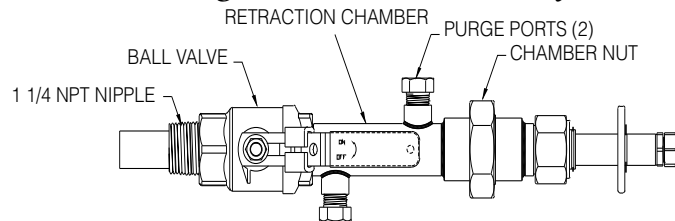

The Ball Valve assembly requires the use of a PH12 120 mm (4.7") sensor.

1. Loosen the chamber nut and remove the insertion tube assembly as shown in Figure 18.
2. Close the Ball Valve by turning the handle so that it is perpendicular to the housing.
3. Screw the 1 ¼ NPT nipple of the Ball Valve into the process vessel. Tighten as required.

Figure 17. Retraction Chamber

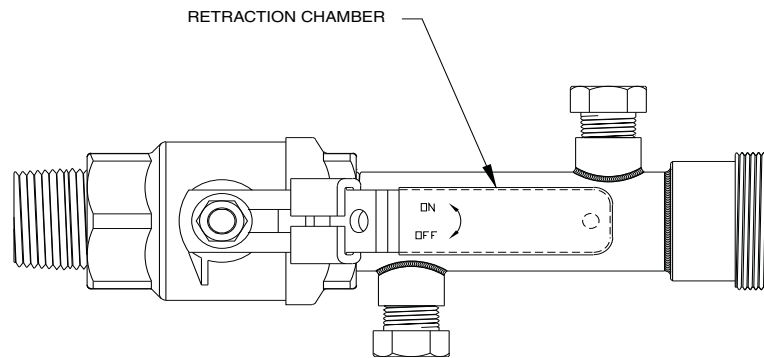
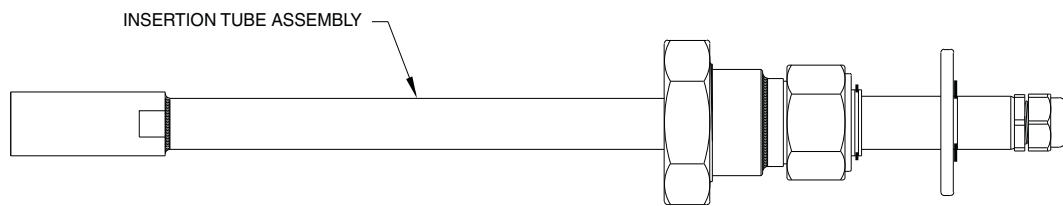

Figure 18. Insertion Tube Assembly



4. Connect the appropriate piping to the purge ports of the retraction chamber.

Installing the Sensor into the Insertion Tube Assembly

⚠ WARNING

Do not exceed the sensor or Ball Valve Insertion Assembly temperature and pressure limits.

1. Thread the PH12 sensor into the metal guarded holder.

Figure 19. Installing PH12 Sensor into Guarded Sensor Holder

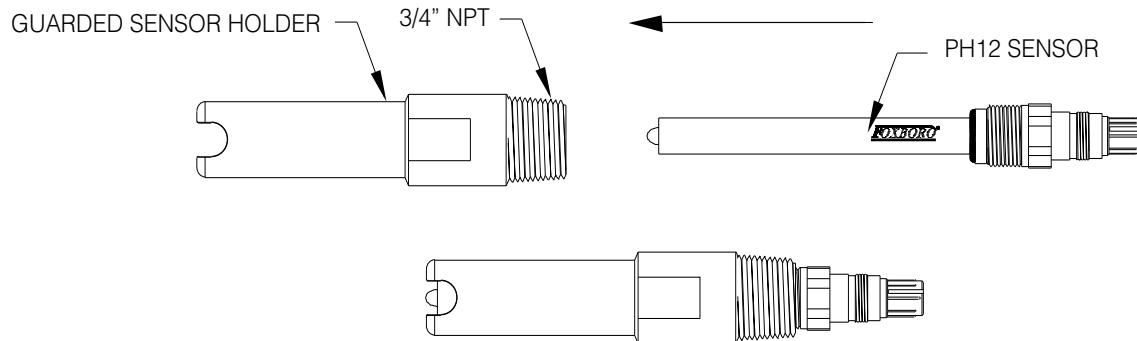

2. Remove the cable strain relief fitting from the insertion tube.
3. Wrap the $\frac{3}{4}$ NPT thread on the PH12 guarded holder.
4. Insert the Variopin patch cord into the insertion tube and make the connection to the sensor.
5. Tighten the sensor into the insertion tube.

Figure 20. Installing Sensor into the Insertion Tube Assembly

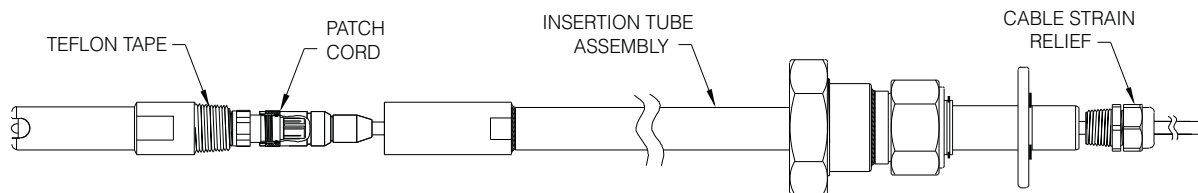

— NOTE —

To prevent the cable from twisting, it is recommended that this be done by holding the sensor and turning the insertion tube.

6. Slide the cable strain relief fitting on to the cable. Screw the fitting into the insertion tube and tighten as required. Tighten the strain relief until it captures the cable.

Installing the Insertion Tube into a Ball Valve

Figure 21. Installing Insertion Tube into Ball Valve

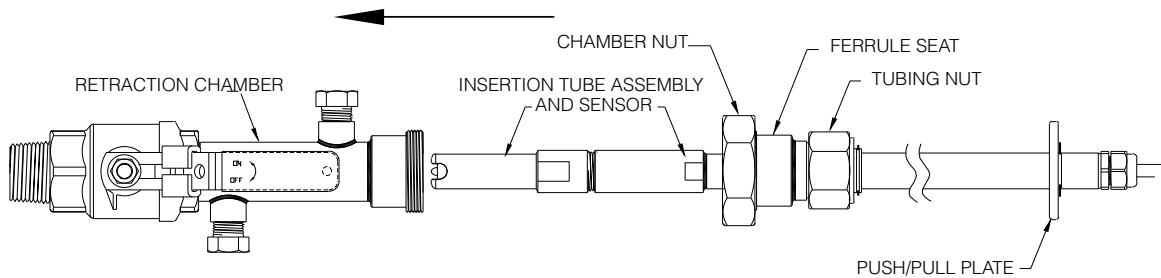

WARNING

Do not exceed the sensor or Ball Valve Insertion Assembly temperature and pressure limits.

NOTE

The sensor should be installed into the insertion tube and the retraction chamber installed into the process prior to performing this procedure. See “Installing the Ball Valve Assembly into the Process - Model BVA-PHD” on page 27 and “Installing the Sensor into the Insertion Tube Assembly” on page 28.

1. Loosen the tubing nut and slide the ferrule seat along the insertion tube towards the sensor end as far as it goes. Slightly tighten the tubing nut.

CAUTION

Failure to perform Step 1 makes it possible for the sensor to contact the closed Ball Valve while performing Step 2. Such contact could damage the sensor.

2. Insert the sensor end of the insertion assembly into the retraction chamber and tighten the chamber nut.
3. Secure the ferrule seat in place on the insertion tube by tightening the tubing nut.
4. Slowly open the Ball Valve by turning the handle so that it is parallel to the housing.

WARNING

Depending on the condition of the ferrule seat O-rings, process seepage is possible as you perform the next step. Take all necessary precautions.

CAUTION

Failure to open the Ball Valve caused the sensor to contact the closed Ball Valve when performing Step 5. Such contact could damage the sensor.

- Slightly loosen the tubing nut and insert the insertion tube assembly to the required depth. Retighten the tubing nut.

— **NOTE** —

When the push / pull plate is in contact with the tubing nut, the sensor is inserted at the maximum depth 20 cm (8 in), 40 cm (16 in), 60 cm (24 in), 80 cm (32 in), etc.

Removing and Replacing the Sensor

⚠ WARNING

If process fluids are present, there could be some process seepage as you perform Steps 1, and 4. Take all necessary precautions.

- Refer to Figure 22. Slightly loosen the tubing nut and pull the insertion tube assembly out of the process as far as you can. Retighten the tubing nut.

Figure 22. Removing and Replacing the Sensor

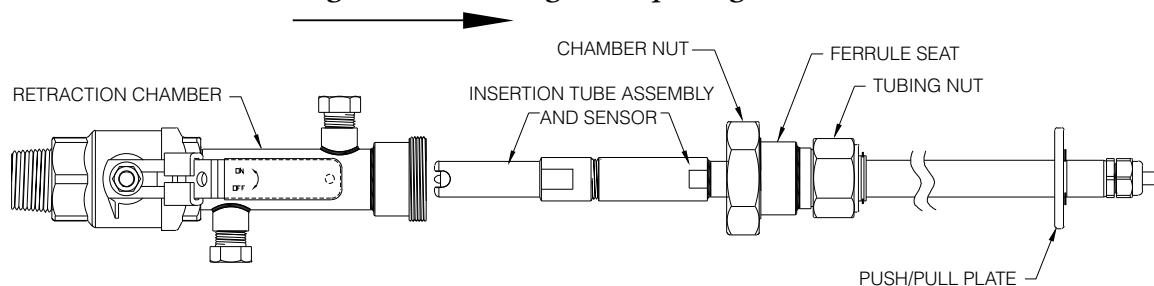

- Close the Ball Valve by turning the handle so that it is perpendicular to the housing.
- Flush and drain the purgeable retraction chamber. Then close the purge fittings.
- Slowly unscrew the chamber nut and remove the insertion tube assembly.
- Loosen the cable strain relief fitting from the cable.
- Unscrew and remove the sensor and guarded adapter from the insertion tube assembly.
- Disconnect the patch cord from the Variopin connector on the sensor.
- Unscrew and remove the sensor from the metal guarded adapter.
- To replace the sensor reverse the above steps. See “Installing the Sensor into the Insertion Tube Assembly” on page 28 and “Installing the Ball Valve Assembly into the Process - Model BVA-PHD” on page 27 for more detailed instructions.

Replacing O-Ring Seals and the Split Washer in the Ferrule Seat

1. Perform Steps 1 through 4 of “Removing and Replacing the Sensor” on page 30.

Figure 23. Replacing O-Ring Seals and Split Washer in the Ferrule Seat

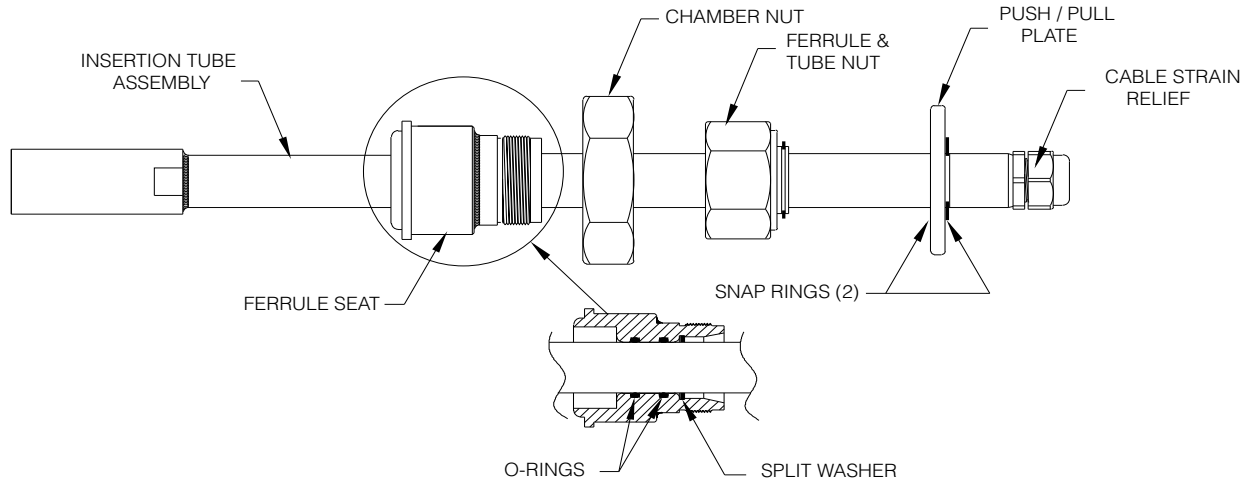

2. Referring to Figure 23, remove the cable strain relief fitting from the insertion tube.
3. Remove the two snap rings and the push / pull plate.
4. Remove the tubing nut with ferrule and chamber nut and ferrule seat.
5. Remove the two O-rings from the inside of the ferrule seat and the split washer.
6. Grease the new O-rings and liberally grease the inside of the ferrule seat. Insert the new O-rings into the ferrule seat, and then insert the split washer.
7. Grease the insertion tube assembly and reinstall the parts removed in Steps 4, 3, and 2.
8. See “Installing the Sensor into the Insertion Tube Assembly” on page 28 and “Installing the Ball Valve Assembly into the Process - Model BVA-PHD” on page 27.

Wiring

Cable Variations

Patch cords are used with the sensor. A standard length patch cord is 10 feet. Optional lengths are 20, 30, 40, or 50 feet. The patch cord has a Variopin connector on the sensor end and straight pin lugs on the other end. The patch cords can be used with an extension cable (with straight pin lugs on each end). See Figure 24 for typical patch cord and extension cable configurations.

Cable Length

When a remote preamplifier is used, the analyzer/transmitter can be up to 152 m (500 ft) away from the sensor. If no preamplifier is used, the distance is limited to 15 m (50 ft).

Figure 24. Cable Length

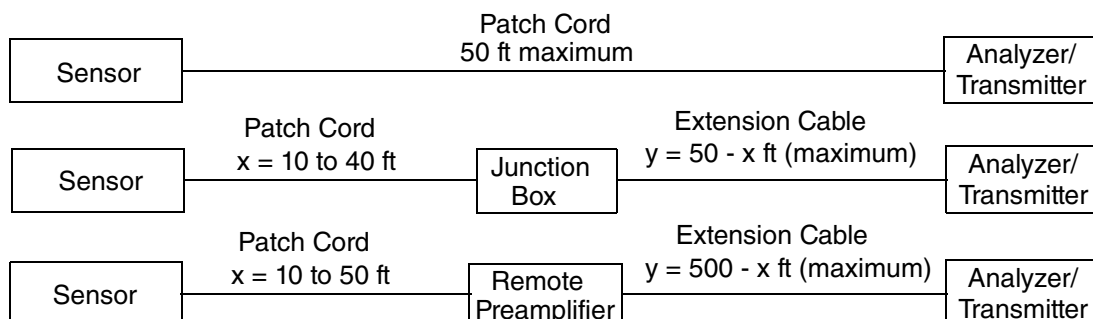

Connections to Analyzer or Transmitter

Connect the numbered wires from the patch cord or extension cable to the appropriate terminals on the transmitter, analyzer, junction box, or remote preamplifier. For sensor connections to an analyzer or transmitter, refer to Table 6 through Table 8. Extension cables have the same numbering and color coding as the patch cords.

Table 6. Analyzer and Transmitter Connections

Instruction	Analyzer or Transmitter
MI 611-165	873PH Series Electrochemical Analyzers for pH or ORP Measurement
MI 611-190	873DPX Dual pH, ORP, or ISE Electrochemical Analyzers
MI 611-191	873APH Ace Series Electrochemical Analyzers for pH Measurement
MI 611-211	870ITPH pH and ORP Transmitters
MI 611-225	875PH pH and ORP Analyzers
MI 611-262	876PH pH and ORP Transmitters

NOTE

When used with analyzers and transmitters of other companies, refer to our Global Customer Support Center at 1-866-746-6477.

Table 7. Standard Temperature Cable Wiring

Wire Number	Cable Color	Function
1	Black	RTD
2	Dark Green	RTD
2A	White	RTD 3-Wire (see note)
3	Clear (Coax)	Measuring Electrode
3A	Clear (Coax Shield)	Coax Shield (screen) for Measuring Electrode
4	Green (Outer Shield)	Solution Ground
5	Red	Reference Electrode

NOTE
Wire 2A is not used with 873 Analyzers. In such applications, it should be taped back.

Table 8. High Temperature Cable Wiring

Wire Number	Cable Color	Function
1	Black	RTD
2	Brown	RTD
2A	Orange	RTD 3-Wire (see note)
3	White (Coax)	Measuring Electrode
3A	Clear (Coax Shield)	Coax Shield (screen) for Measuring Electrode
4	Green (Outer Shield)	Solution Ground
5	Red	Reference Electrode

NOTE
Wire 2A is not used with 873 Analyzers. In such applications, it should be taped back.

Variopin Connectors

Do **not** disconnect the patch cord from the sensor in the rain or in condensing moisture environments or otherwise allow moisture to get inside the connector. Before assembly, inspect the two parts of the connector for any sign of moisture or residue. Thoroughly remove any moisture or residue from all surfaces to ensure high performance.

Even though the Variopin connector meets the ingress protection standards of IEC IP66 and IP68 for submersion at a depth of 2 m for 48 hours, connectors should not be used in long term submersion/immersion installations.

3. Troubleshooting

Use the following procedure for diagnosing and correcting sensor problems:

1. Enable all sensor diagnostics when using an 875PH Analyzer or an 870ITPH or 876PH Transmitter. Check the diagnostic status for messages and corresponding actions.
2. Check RTD.P

PH12 series sensors use 100 ohm 3-wire RTDs or 1000 ohm 3-wire RTDs.

Disconnect sensor leads 1, 2, and 2a from the analyzer or transmitter and use an ohmmeter to measure the resistance between 1 and 2 and 1 and 2a. Resistance with temperature values for the RTDs are shown in Table 9. Leads 2 and 2a are common; the resistance between them should be small or effectively zero.

If these checks are OK, proceed to Step 3.

Table 9. Process Temperature vs. RTD Resistance

Process Temperature		100 ohm RTD Resistance	1000 ohm RTD Resistance
°C	°F	Ohms	Ohms
-30	-22	88.222	882.22
-20	-4	92.160	921.60
-10	14	96.086	960.86
0	32	100.00	1000.0
10	50	103.90	1039.0
20	68	107.79	1077.9
25	75	109.73	1097.3
30	86	111.67	1116.7
40	104	115.54	1155.4
50	122	119.40	1194.0
60	140	123.24	1232.4
70	158	127.07	1270.7
80	176	130.89	1308.9
90	194	134.70	1347.0
100	212	138.50	1385.0
110	230	142.28	1422.8
120	248	146.06	1460.6
130	266	149.82	1498.2
140	284	153.57	1535.7

3. Check the system with buffers.

Conduct this check with all leads connected to the analyzer / transmitter and with the analyzer/transmitter power on. Clean the pH electrode (see “Cleaning a Glass Electrode” on page 38) and reference junction (see “Cleaning the Reference Junction” on page 38). Place sensor in a pH 7 buffer solution.

- a. With an 875PH Analyzer or 876PH or 870ITPH Transmitter, use the Status menu to display the voltage of the sensor.
- b. With an 873 Analyzer, press SHIFT and mV.

The reading should be approximately 0 mV in a pH 7 buffer and should change approximately 59 mV per pH unit (for example, in pH 4 buffer, the reading should be approximately +177 mV; in pH 10 buffer, the reading should be approximately -177 mV).

If above check is OK and there is still a problem with the measurement, the problem resides in the analyzer or transmitter.

Table 10. Sensor Troubleshooting

Problem	Possible Cause	Remedy
No response.	1. Broken measuring electrode. 2. Heavily coated electrodes.	1. Replace sensor. 2. Clean electrodes.
Elongated span.	1. Incorrect instrument calibration 2. Instrument temperature compensation inactive or incorrectly configured. 3. Incorrect temperature measurement.	1. Recalibrate. 2. Refer to instrument manual for proper configuration. 3a. Check that analyzer /transmitter is configured for correct RTD. 3b. Check RTD resistance across leads 1 and 2 (see Table 9). 3c. If OK, calibrate instrument temperature circuit. If bad, replace sensor.
Sluggish response.	1. Aged or dehydrated measuring electrodes. 2. Coated or dirty electrodes.	1. If sensor is dehydrated, soak in pH 4 buffer or KCl solution. 2a. Clean electrodes. 2b. Replace sensor.
Erratic or noisy measurement.	1. Fouled reference junction. 2. Air bubbles in the process.	1. Clean reference junction. 2. Arrange sensor mounting to avoid air bubbles.
Discrepancy between process reading and laboratory grab sample results.	1. Laboratory reading in error. 2. Change in grab sample temperature (that is, sample temperature changed before laboratory measurement was made — causing a change in pH). 3. Incorrect instrument calibration.	1. Verify calibration and/or operation of laboratory pH equipment. 2. Make off-line measurement as soon as possible after collecting grab sample. If sample cooling is inevitable, a change in pH from the process to the lab may be unavoidable. 3. Perform single point calibration to make readings agree.

4. Maintenance

Calibration

Your sensor and analyzer/transmitter system should be calibrated regularly. A sensor loses calibration for two general reasons: the slope changes or the offset changes. Slope changes are usually due to aging of the measuring electrode. Offset changes are often due to clogging and contamination of the reference junction. A single point calibration corrects the offset only. A two point calibration corrects both the offset and the slope. Frequency of calibration is dictated by the rigors of the process, such as temperature, pressure, abrasives, harsh chemicals, and so forth. It is also related to your requirement for accuracy. Many users do a single point, grab sample calibration frequently and a two point calibration only occasionally. Refer to your analyzer/transmitter instruction for specific calibration procedures.

Temperature Calibration

PH12 sensors include a precision temperature measuring element. Foxboro analyzers and transmitters use this temperature measurement to provide automatic temperature compensation of the pH measurements.

For optimum pH measurement accuracy, the temperature measurement accuracy should be checked and adjusted if necessary. This is especially important when a long cable length is used. PH12 Sensors contain 3-wire RTD elements that automatically compensate for errors due to cable length. Refer to your analyzer/transmitter instruction for specific calibration procedures.

Electrode Inspection

Fouling (the build-up of a film) on the measuring electrode and the reference junction can cause erratic output.

Inspect the electrodes as needed. Once a week is recommended for new installations. If fouling is evident, clean the electrode as described in the following sections.

Electrode Cleaning

Cleaning a Glass Electrode

First, consider the contamination you are trying to remove. In what is it soluble? What will chemically attack it? Next, consider the sensor. What cleaner will have little or no effect on the sensor itself? Choose the solvent, soap, or chemical that is the mildest but removes the contamination. Caustic is a risky choice for glass electrodes. Stronger concentrations can attack the glass. Dilute HCl (muriatic acid) is frequently a good choice. The concentration of HCl should be as low as possible and still remove the contamination. Consider 4% or 1 N to be a maximum.

— NOTE

A Foxboro brand electrode reconditioning solution is offered for very extreme applications. Contact Global Customer Support for more information on when this solution should be used, and how to specify it.

CAUTION

Do not clean glass electrodes with abrasive cleaners or coarse wipers.

CAUTION

Handle the sensor very carefully to avoid damage to the glass electrode.

Rinse the electrode with distilled water. Blot the electrode and reference junction with a soft cloth. In hard-water areas, dip the tip of the sensor in a 1 to 4% solution of HCl to remove surface film. Then rinse thoroughly.

If the electrode surface is oily, clean it with a mild detergent and fine bristle brush.

Cleaning an ORP Electrode

ORP electrodes rarely require cleaning. However when they do, first consider the contamination you are trying to remove. In what is it soluble? What will chemically attack it? Next, consider the sensor. What cleaner will have little or no effect on the sensor itself? Choose the solvent, soap, or chemical that is the mildest but removes the contamination. The electrode surface can also be polished with powdered alumina or a fine grained emery cloth.

Cleaning the Reference Junction

Carefully clean the reference junction with detergent and a fine bristle brush.

Sanitizing the Sensor

The PH12 Sensor may also be sanitized via an autoclave and other steam sanitizing process.

However, before subjecting the sensor to this process, screw the autoclave cap (option -A) onto the variopin end of the sensor to protect the electrical contacts.

Storing a Sensor

The shelf life of your sensor depends on the storage conditions. Although a specific shelf life is not specified, a reasonable estimate is 6 to 12 months. Under the best conditions, sensors may last well over a year on the shelf.

When stored, the measuring electrode and the reference junction should be kept hydrated at normal room temperature. Store your PH12 Sensor in a 1 M (or higher) potassium chloride solution or a pH 4 or pH 7 buffer solution. Sensors should not be stored in distilled or deionized water. New sensor assemblies are shipped with the measuring and reference junction sealed in a protection container with liquid potassium chloride salt solution. The container should remain in place until you are ready to install your sensor in the process. The container can be reused to store a sensor by replenishing the solution and fitting it (in two steps) on to the sensor. First twist the container cap onto the sensor and then screw on the container bottle into the cap. This is recommended if the sensor is removed from the process for more than a few hours. Proper storage maximizes both shelf life and service life of a sensor.

ISSUE DATES

SEP 2009	SEP 2012
OCT 2009	JUL 2015
AUG 2010	SEP 2015
MAR 2011	FEB 2016

Vertical lines to the right of text or illustrations indicate areas changed at last issue date.

Foxboro[®]
by Schneider Electric

Invensys Systems, Inc.
38 Neponset Avenue
Foxboro, MA 02035
United States of America
<http://www.fielddevices.foxboro.com>

Global Customer Support
Inside U.S.: 1-866-746-6477
Outside U.S.: 1-508-549-2424
Website: <http://support.ips.invensys.com>

Copyright 1999-2016 Invensys Systems, Inc.
All rights reserved.

Invensys, Foxboro, and I/A Series are trademarks of
Invensys Limited, its subsidiaries, and affiliates. All other
trademarks are the property of their respective owners.

Invensys is now part of Schneider Electric.