

FT10 Series
Flow-Through Conductivity Sensors

Installation, Calibration, Troubleshooting, and Maintenance

Contents

Figures	5
Tables	7
1. Introduction	9
Description	9
Reference Documents	9
Standard Specifications.....	9
Ambient Temperature Limits.....	9
Process Pressure/Temperature Limits	9
Flare Tube Fitting End Connections	10
Nippon Super Pillar 300 Fitting End Connections	10
Temperature Compensation	10
Materials	11
Approximate Sensor Weight	11
Electrical Safety Specifications.....	12
Pressure Equipment Directive (PED) Compliance	12
Ingress Protection.....	12
Model Code.....	13
2. Installation	15
Sensor Identification	15
Sensor Mounting.....	15
Mounting Considerations.....	15
Location	15
Piping Size.....	16
Sensor Position	16
Protective Plug.....	16
Supporting Mating Piping.....	16
Tightening Flare Tube Connections.....	17
Tightening Nippon Super Pillar 300 Connections.....	17
Mounting Bracket	17
System Wiring.....	18
Wiring to 875EC Analyzers.....	18
Wiring to 870ITEC Transmitters	19
Cable Length.....	20

3. System Calibration	21
Bench Calibration	21
Entering Data Into Analyzer or Transmitter.....	22
Calibration Using Calibration Plugs	23
Calibration at Low End Value.....	23
Calibration at Full Scale Value	23
Calibration Using a Calibration Cable.....	24
Calculating (Low End) Resistance Value.....	24
Calculating (Full Scale) Resistance Value	24
Calibration Procedure.....	25
Solution Calibration.....	26
Enter Data Into Analyzer or Transmitter.....	26
Calibration Procedure.....	27
4. Troubleshooting and Maintenance	29
Troubleshooting	29
Maintenance	29
Return Policy	29
Warranty	30
Index	31

Figures

1	Sample FT10 Sensor Data Label	15
2	Mounting Positions.....	16
3	Examples of Various Mounting Techniques	18
4	Sensor Wiring to 875EC Analyzer.....	19
5	Sensor Wiring to 870ITEC Transmitter	19
6	FT10 Calibration with Calibration Plug	23
7	FT10 Calibration with Calibration Cable	25

Tables

1	Reference Documents	9
2	Temperate vs RTD Resistance	11
3	Electrical Safety Specifications	12
4	Torque for Flare Tube Connections	17
5	Geometric and Electrical Cell Factors.....	22
6	Minimum and Maximum Full Scale Conductivity Ranges.....	23
7	Symptoms, Possible Causes, and Remedies.....	29

1. Introduction

Description

The FT10 Flow-Through Electrodeless Conductivity Sensor is a noninvasive sensor featuring all PFA (Teflon) wetted parts packaged in a chemically resistant rectangular housing. It is designed to be used to measure aqueous (non-slurry) solutions. It employs the patent-pending multi-toroid design to provide its accurate and reliable capability. Conductivity measurement is possible to 2000 mS/cm.

The sensor is available in 1/2-, 3/4-, and 1-inch sizes with Flare Tube Fitting or Nippon Super Pillar 300 Tube Fitting end connections. Temperature compensation is accomplished via an internal 100 Ω or 1000 Ω , 3-wire RTD.

Both the conductivity signal and the temperature measurements are conveyed to an 875EC Analyzer or 870ITEC Transmitter via an integral cable or patch cord connection. Calibration is accomplished via a calibration cable and a decade box or a Foxboro EP485F Series precision resistance calibration plug.

Reference Documents

Table 1. Reference Documents

Document	Description
DP 611-217	Dimensional Print - FT10 Conductivity Sensors
MI 611-224	Instruction - 875EC Intelligent Electrochemical Analyzer
MI 611-212	Instruction - 870ITEC Intelligent Electrochemical Transmitter
MI 611-220	Instruction - System Calibration Examples
PL 611-141	Parts List - FT10 Conductivity Sensors and Accessories
TI 612-005	Electrodeless Conductivity, Toroidal Magnets and the Procedure for Degaussing
Bul EP485F	EP485F Precision Resistance Calibration Plug

Standard Specifications

Ambient Temperature Limits

-10 and +65°C (14 and 149°F)

Process Pressure/Temperature Limits

Process Pressure Limits: 0 and 100 psi

Process Temperature Limits: -5 and +140°C (21 and 284°F)

— NOTE

Maximum pressure rated does not necessarily correspond to an actual liquid state. Your process fluid may not remain a liquid at high temperatures and as a result could produce a vapor pressure which exceeds the pressure limit. Use industry standard protocol in maintaining the temperature and pressure ratings exactly as defined below.

Flare Tube Fitting End Connections

Tube/Line Size	Pressure/Temperature Rating
Code 08 (1/2 inch)	100 psi to 194°F (90°C) Linearly derated to 60 psi at 284°F (140°C)
Code 12 (3/4 inch)	100 psi to 86°F (30°C) Linearly derated to 76.5 psi at 140°F (60°C) Linearly derated to 53 psi at 194°F (90°C) Linearly derated to 33 psi at 248°F (120°C) Linearly derated to 26 psi at 284°F (140°C)
Code 16 (1 inch)	75 psi to 75°F (24°C) Linearly derated to 56 psi at 140°F (60°C) Linearly derated to 40 psi at 194°F (90°C) Linearly derated to 28 psi at 248°F (120°C) Linearly derated to 20 psi at 284°F (140°C)

Nippon Super Pillar 300 Fitting End Connections

Tube/Line Size	Pressure/Temperature Rating
Code 08 (1/2 inch)	100 psi to 140°F (60°C) Linearly derated to 64 psi at 284°F (140°C)
Code 12 (3/4 inch)	100 psi to 86°F (30°C) Linearly derated to 76.5 psi at 140°F (60°C) Linearly derated to 53 psi at 194°F (90°C) Linearly derated to 33 psi at 248°F (120°C) Linearly derated to 26 psi at 284°F (140°C)
Code 16 (1 inch)	100 psi to 140°F (60°C) Linearly derated to 64 psi at 284°F (140°C)

Temperature Compensation

Temperature measurement is included. An internal RTD makes a temperature measurement using a unique design integral to the flowtube but isolated from the process flow. The RTD is a 100 Ω or 1000 Ω 3-wire platinum RTD as ordered. The RTD wires terminate in the sensor cable or integral connector depending on which termination is included on your sensor.

The resistance/temperature response is per DIN 43760 or IEC 751-1983. The resistance at various temperatures is shown in Table 2.

Table 2. Temperature vs RTD Resistance

Temperature		Resistance (Ω)	
$^{\circ}\text{C}$	$^{\circ}\text{F}$	100 Ω RTD	1000 Ω RTD
0	32	100.00	1000.0
10	50	103.90	1039.0
20	68	107.79	1077.9
25	77	109.73	1097.3
30	86	111.67	1116.7
40	104	115.54	1155.4
50	122	119.40	1194.0
60	140	123.24	1232.4
70	158	127.07	1270.7
80	176	130.89	1308.9
90	194	134.70	1347.0
100	212	138.50	1385.0
110	230	142.28	1422.8
120	248	146.06	1460.6
130	266	149.82	1498.2
140	284	153.58	1535.8

Materials

Process Wetted: PFA (Teflon) Perfluoroalkoxyethylene

Enclosure, Mounting Bracket, and Calibration Connector Cover:
Ultra High Molecular Weight Polyethylene (UHMWPE)

Calibration and Signal Connectors: Nickel Plated Brass

Calibration Connector Cover Integral O-ring: Viton

Mounting Bolts: Nylon

U-Bolts: Polyurethane

Approximate Sensor Weight

Tube/Line Size per Model Code	Approximate Weight	
	kg	pounds
08 = 1/2 Inch	1.3	2.9
12 = 3/4 Inch	1.6	3.6
16 = 1 Inch	3.9	8.5

Electrical Safety Specifications

— NOTE —

These sensors have been designed to meet the electrical safety descriptions listed in Table 3. For detailed information or status of testing laboratory approvals/certifications, contact Global Customer Support.

Table 3. Electrical Safety Specifications

Testing Laboratory, Type of Protection, and Area Classification	Application Conditions	Electrical Safety Design Code
ATEX intrinsically safe EEx ia IIC, Zone 0.	Connect to certified 870ITEC Transmitter ^(b) per MI 611-208. Temperature Class T4 - T6.	CS-E/AAA
ATEX Type n energy limited EEx nL IIC, Zone 2.	Connect to certified 875EC Analyzer or 870ITEC Transmitter ^(b) per MI 611-208. Temperature Class T4 - T6.	CS-E/ANN
FM/FMC ^(a) intrinsically safe for Class I, Division 1, Groups A, B, C, and D; Class II, Division 1, Groups E, F, and G; Class III, Division 1.	Connect to approved 870ITEC Transmitter ^(b) per MI 611-206. Temperature Class T6.	CS-E/FAA
FM/FMC ^(a) nonincendive Class I, Division 2, Groups A, B, C, and D; Class II, Division 2, Groups E, F, and G; Class III, Division 2.	Connect to approved 875EC Analyzer or 870ITEC Transmitter ^(b) per MI 611-206. Temperature Class T6.	CS-E/FNN
IECEx intrinsically safe Type ia protection; Ex ia IIC, Zone 0	Connect to certified 870ITEC Transmitter ^(b) . Temperature Class T6, Ta = 65°C.	CS-E/DAA
IECEx nonsparking Type n protection; Ex nA IIC, Zone 2.	Connect to certified 875EC Analyzer or 870ITEC Transmitter ^(b) . Temperature Class T6, Ta = 65°C.	CS-E/DNN

(a) FMC is FM certified to Canadian standards for use in Canada.

(b) or other equipment with compatible entity parameters.

Pressure Equipment Directive (PED) Compliance

FT10 Sensors are in compliance with the Pressure Equipment Directive 97/23/EC as Sound Engineering Practice (SEP).

Ingress Protection

Provides NEMA 4X and IEC IP66 protection.

⚠ WARNING

Patch cable or protective cap must be securely installed to meet ingress protection ratings on integral connection version (FT10-MT###6).

⚠ WARNING

Calibration connection cap must be securely installed to meet ingress protection ratings.

Model Code

<u>Noninvasive, Nonmetallic Electrodeless Flow-Through Conductivity Sensor</u>	FT10
<u>Electrodeless Conductivity</u>	
All Teflon Flow-Through Sensor	-MT
<u>Tube/Line Size</u>	
1/2 inch	08
3/4 inch	12
1 inch	16
<u>End Connection Form</u> ^{(a)(b)}	
Flare Tube Fitting	F
Nippon Super Pillar 300 Fitting	N
<u>Termination</u>	
Integral Sensor Cable ^(c)	1
Integral High-Temperature Sensor Cable ^(c)	2
Integral Connector ^(d)	6
<u>RTD</u>	
100 Ohm, 3-Wire	T
1000 Ohm, 3-Wire	R
<u>Options</u>	
Surface Mounting Kit	-1
Pipe Mounting Kit	-2
Cable Length Per Sales Order ^(e)	-3
Specific Sensor Geometric Cell Factor ^(f)	-4

Notes

(a) Provides the corresponding connection size for the line size selected. For example, Selecting Tube/Line Size Code 08 (1/2 in tube/line size) and End Connection Form Code N (Nippon Super Pillar 300) results in a 1/2 inch Nippon Super Pillar 300 connector.

(b) Bond (bare) tube end available as an accessory adapter to either Flare or Nippon end connection.

(c) Standard length integral cable is 10 feet (3 meters).

(d) Requires mating patch cord.

(e) Not available with Termination selection 6.

(f) Determined experimentally at factory. Contact Global Customer Support.

2. Installation

Sensor Identification

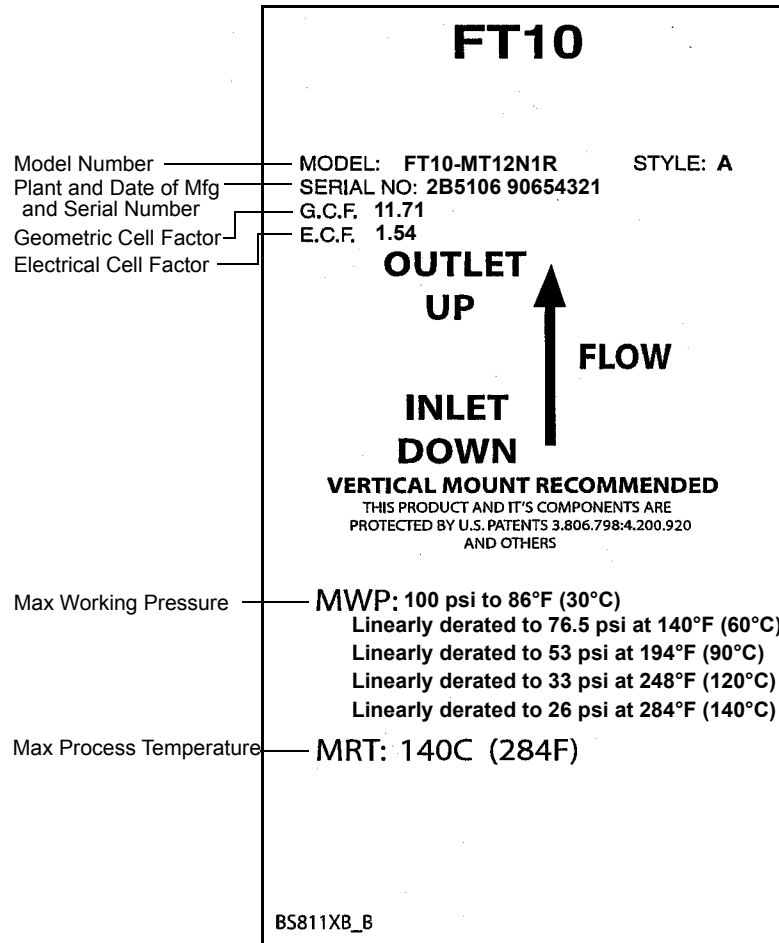

Figure 1. Sample FT10 Sensor Data Label

Sensor Mounting

Refer to DP 611-217 for dimensional information.

Mounting Considerations

To ensure optimum performance, consider the following when installing your sensor:

Location

Do **not** mount the FT10 Sensor within 1 m (3 ft) of any magnetic motor.

Do **not** mount the FT10 Sensor with extended exposure to UV radiation (sunlight) because the housing material may yellow and become brittle.

Piping Size

The inside diameter of the piping should be the same as or larger than the nominal size of the sensor bore. Sensors can be placed in larger nominal size pipelines by using tapered conical reducers. The small end of the reducers can be directly coupled to the sensor.

Sensor Position

For accuracy, it is essential that the tube be completely full during operation as the presence of entrained air or bubbles within the sensor may lead to errors in measurement proportional to the volume of fluid they displace. Therefore, vertical flow upward is preferred but sloping positions to horizontal are acceptable. Always position the inlet port lower than the outlet port. See Figure 2.

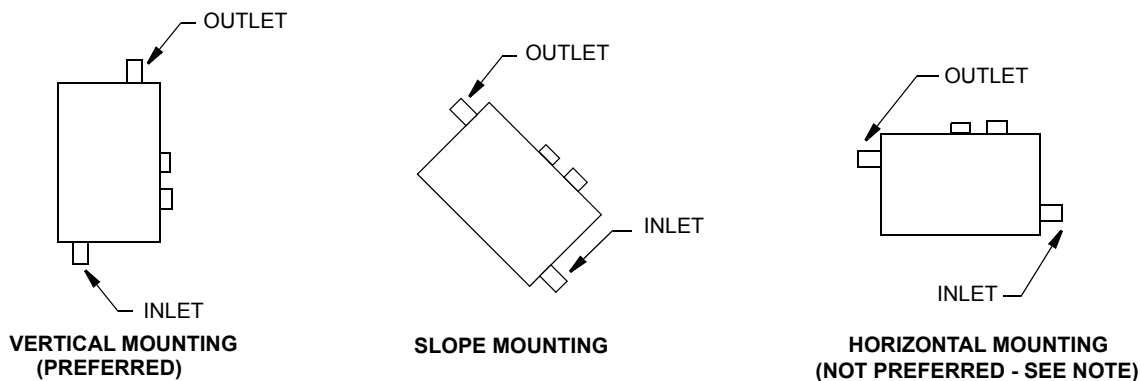

Figure 2. Mounting Positions

NOTE

After a horizontally mounted sensor is connected in the line, prime the sensor at a fluid velocity of 5.35 ft/s to purge all the air from the sensor. The purge rates are as follows:

Code 08 (1/2 inch) tube/line size: 1.9 gpm
 Code 12 (3/4 inch) tube/line size: 5.1 gpm
 Code 16 (1 inch) tube/line size: 10.1 gpm

Protective Plug

There are protective plugs in the inlet and outlet of the sensor. Be sure to remove these plugs before connecting the sensor to the pipeline.

Supporting Mating Piping

When joining the sensor to mating piping, support the piping in a manner that does not introduce unwanted stresses on the sensor end connections.

Tightening Flare Tube Connections

For sensors with Flare Tube connections, tighten at room temperature per Table 4.

— **NOTE** —

If initial exposure of connections reaches a temperature $\geq 74^{\circ}\text{C}$ (165°F), return to room temperature and zero pressure and retighten per Table 4.

Table 4. Torque for Flare Tube Connections

Tube/Line Size	Torque
Code 08 (1/2 inch)	11 lb•in (1.2 N•m)
Code 12 (3/4 inch)	14 lb•in (1.6 N•m)
Code 16 (1 inch)	30 lb•in (3.4 N•m)

Tightening Nippon Super Pillar 300 Connections

For sensors with Nippon Super Pillar 300 connections, hand tighten plus 1/4 turn at room temperature and zero pressure. After tightening, if there is leakage from the fitting, return to room temperature and zero pressure and tighten an additional 1/4 turn.

— **NOTE** —

Once leakage occurs, the liquid may remain in the nut, resulting in a liquid exuding from the fitting for a while after retightening the union nut.

Mounting Bracket

The FT10 Sensor comes with mounting hardware to mount the sensor various ways. See examples in Figure 3.

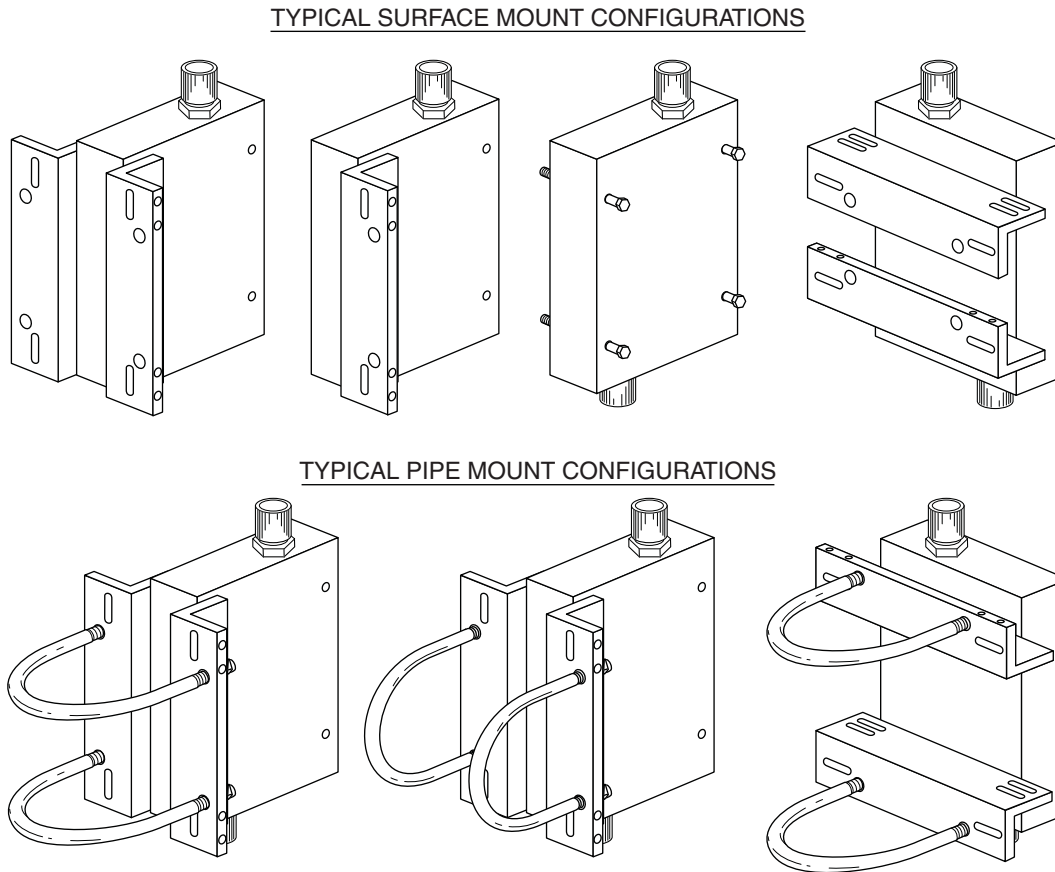

Figure 3. Examples of Various Mounting Techniques

System Wiring

Sensors with Termination Code 1 (PVC-jacketed cable) can be used in ambient temperatures up to 105°C (221°F). Those with Termination Code 2 (Teflon-jacketed cable) can be used in ambient temperatures up to 200°C (392°F). Sensors with Termination Code 6 have an integral connector that requires a patch cord (also available in PVC- or Teflon-jacketed material).

The PVC-jacketed cable or patch cord is suitable for use in applications where conduit provides RFI/EMI shielding and electrically interconnects with the sensor and the ground on the analyzer/transmitter. The Teflon-jacketed cable or patch cord has integral RFI/EMI shielding.

Wiring to 875EC Analyzers

Wiring connections on 875EC panel-mounted analyzers are located on the rear of the housing. Those on pipe- or surface-mounted analyzers are located in the lower compartment of the housing. Connect sensor leads 1 through 8 per Figure 4. With teflon-jacketed cable, connect sensor lead 9 to case ground. To meet CE requirements, the ac power cable must be routed away from all other I/O wiring, especially the sensor cable.

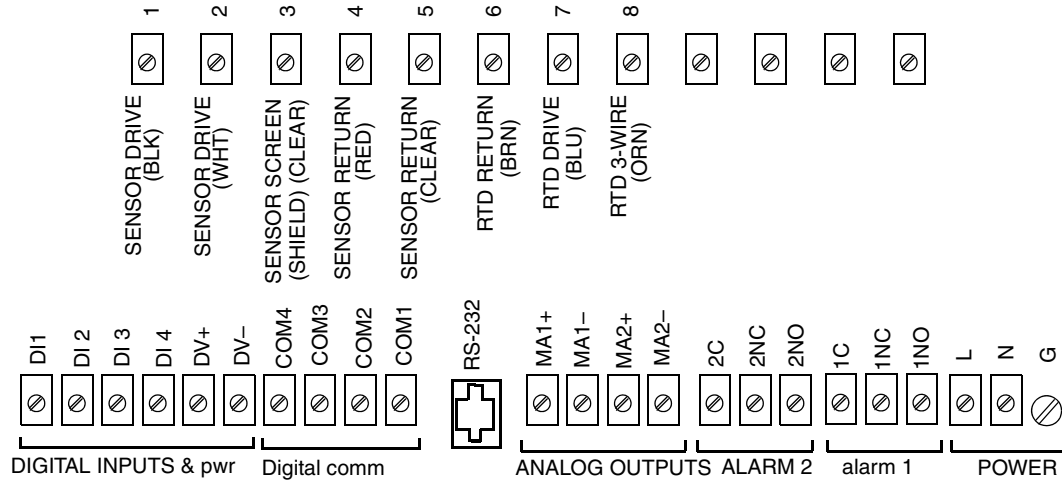

Figure 4. Sensor Wiring to 875EC Analyzer

Wiring to 870ITEC Transmitters

When wiring sensors to 870ITEC Transmitters using standard PVC jacketed cable, Leads 1 through 8 are connected to the corresponding numbered terminals in the analyzer. With teflon-jacketed cable, connect sensor lead 9 to case ground.

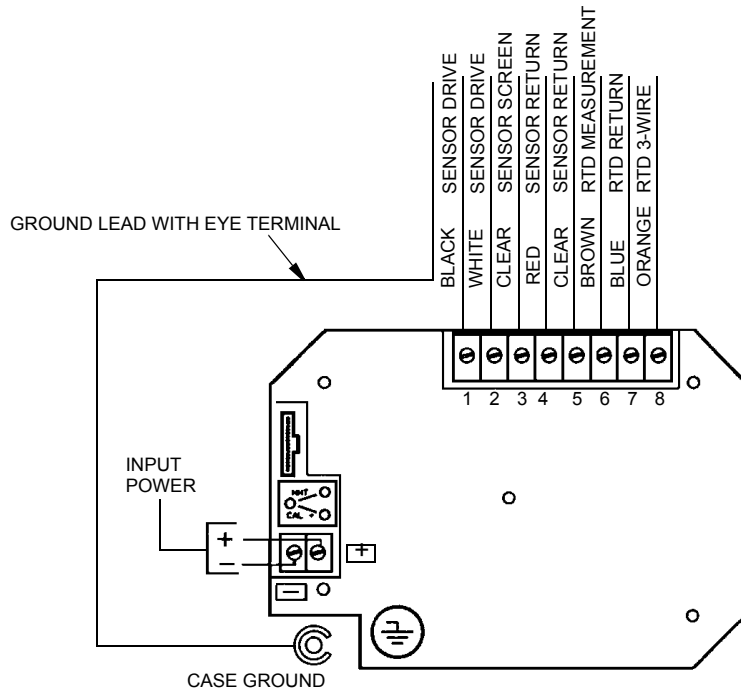

Figure 5. Sensor Wiring to 870ITEC Transmitter

Cable Length

The sensor can be located up to 100 ft (30 m) from the analyzer/transmitter. For convenience, a junction box can be used anywhere between the sensor and the analyzer/transmitter as long as the total distance between the sensor and the analyzer/transmitter does not exceed 100 ft (30 m).

3. System Calibration

The FT10 Flow-Through Electrodeless Conductivity Sensor, when connected to an 875EC Analyzer or 870ITEC Transmitter is calibrated as a system using either of two procedures; a 'Bench Calibration' using resistances or a 'Solution Calibration' using solutions.

⚠ CAUTION

All electrodeless sensors can become magnetized if they come in close proximity to magnetic sources such as motors or electrical lines carrying high current. If this occurs, the measurement values obtained may be in error, particularly at low conductivity ranges (such as less than 500 $\mu\text{S}/\text{cm}$). For this reason, it is recommended that any sensor to be used in a low conductivity application first be degaussed to eliminate any possibility that the sensor has been magnetized either during shipping or on-site. For information on degaussing a magnetized sensor, see TI 612-005. All electrodeless sensors are routinely degaussed prior to shipment.

— NOTE

For step-by-step examples of calibration procedures for FT10 Sensors with 875EC Analyzers and 870ITEC Transmitters, refer to MI 611-220.

Bench Calibration

Since the analyzer or transmitter measures conductance (in S, mS, or μS) and the quantity desired is conductivity (in S/cm, mS/cm, or $\mu\text{S}/\text{cm}$), it is necessary to introduce the geometric cell factor (l/cm) into the calibration procedure. These cell factors are tabulated in Table 5.

Solution Calibration

When a system calibration using solutions is employed, specific knowledge of the geometric cell factor is not required. A standard solution of known conductivity or a sample of process with independently measured conductivity is used for this procedure.

Bench Calibration

— NOTE

It is recommended to calibrate the sensor when the sensor is installed.

To perform a calibration, you must:

1. Enter data into your analyzer or transmitter
2. If using a calibration cable, calculate the low end resistance value
3. Perform a calibration at the low end value
4. Calculate the full scale resistance value
5. Perform a calibration at the full scale value.

Entering Data Into Analyzer or Transmitter

1. Check the model code for the sensor being calibrated. Note the tube/line size.

FT10-MT12F1T
 └─ 08 = 1/2 inch
 12 = 3/4 inch
 16 = 1 inch

2. If using an 875EC Analyzer, select the appropriate sensor in the configuration menu.

Tube/Line Size	Select Sensor Type
Code 08 (1/2 inch)	FT10-08
Code 12 (3/4 inch)	FT10-12
Code 16 (1 inch)	FT10-16

— NOTE —

If using an 875EC Analyzer with firmware version earlier than 2.15, enter the appropriate electronic cell factor $C_{f(elec)}$ from Table 5 for the sensor being used in the configuration menu or contact Global Customer Support to request a firmware upgrade.

3. If using an 870ITEC Transmitter, enter the appropriate electronic cell factor $C_{f(elec)}$ from Table 5 for the sensor being used in the configuration menu.

Table 5. Geometric and Electrical Cell Factors

Tube/Line Size	Cf (geom)	Cf (elec)
Code 08 (1/2 inch)	38.68	5.00
Code 12 (3/4 inch)	11.71	1.54
Code16 (1 inch)	8.08	1.21

4. Check the model code for the sensor being calibrated. Note the RTD type.

FT10-MT12F1T
 └─ T = 100Ω, 3-wire
 R = 1000Ω, 3-wire

Enter the RTD type in the 875EC Analyzer or 870ITEC Transmitter using the appropriate configuration menu.

5. Refer to Table 6 to determine the minimum and maximum full scale conductivity range desired for the system being calibrated.

Enter the desired full scale conductivity range in the 875EC Analyzer or 870ITEC Transmitter using the appropriate configuration menu.

Table 6. Minimum and Maximum Full Scale Conductivity Ranges

Tube/Line Size	Minimum $\mu\text{S/cm}$	Maximum mS/cm
Code 08 (1/2 inch)	2000	2000
Code 12 (3/4 inch)	500	2000
Code 16 (1 inch)	500	2000

Calibration Using Calibration Plugs

Calibration at Low End Value

1. Remove the calibration connector cover.
2. Connect the (low end) Foxboro EP485F calibration plug to the calibration connection on the sensor.

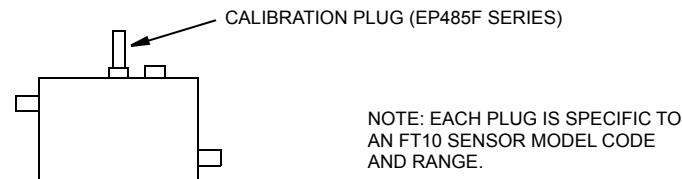
*Figure 6. FT10 Calibration with Calibration Plug*

— NOTE

At high conductivities, if you do not have a low end calibration plug, you may do a low end calibration with infinite resistance (no calibration plug connected to the sensor) at 0.0 $\mu\text{S/cm}$, 0.0 mS/cm or 0.0 S/cm .

3. Using the procedure in the appropriate instruction manual for the analyzer or transmitter being used (MI 611-224 for 875EC or MI 611-212 for 870ITEC), calibrate at the low end value. Also see MI 611-220, System Calibration Examples.
4. Disconnect the calibration plug.

Calibration at Full Scale Value

1. Connect the (full scale) Foxboro EP485F calibration plug to the calibration connection on the sensor. See Figure 6.
2. Using the procedure in the appropriate instruction manual for the analyzer or transmitter being used (MI 611-224 for 875EC or MI 611-212 for 870ITEC), calibrate at the full scale value. Also see MI 611-220, System Calibration Examples.
3. Disconnect the calibration plug and replace the calibration connector cover.
4. Reinstall the sensor into the process if previously removed.

Calibration Using a Calibration Cable

Calculating (Low End) Resistance Value

The low end conductivity value used in calibrating an FT10 sensor is usually about 1% of the full scale value. Use the following formula to calculate low end resistance if using a Foxboro calibration cable with an FT10 sensor.

$$Cf_{(\text{geom})} \cdot 1000 / (LV \text{ in mS/cm}) = \text{Loop R in ohms}$$

where

$Cf_{(\text{geom})}$ = geometric cell factor for the sensor being calibrated, found on the sensor data label.

LV = Low end conductivity value expressed in mS/cm (millisiemens/centimeter).

R = Resistance value, in ohms, to set on the decade resistance box.

Example:

Calibrate an FT10-MT12 Sensor with a range of 0 - 5 mS/cm using a Foxboro calibration cable.

Establish a low end conductivity value (LV) of 0.05 mS/cm.

From the sensor data label, $Cf_{(\text{geom})} = 11.71 \text{ cm}^{-1}$.

From the formula above, $R = (11.71 \cdot 1000) / (0.05) = 234200 \text{ ohms}$.

Calculating (Full Scale) Resistance Value

The resistance required to calibrate your system at full scale value is calculated as follows:

$$\text{Loop R in ohms} = (Cf_{(\text{geom})} \cdot 1000) / (\text{FS in mS/cm})$$

where

$Cf_{(\text{geom})}$ = geometric cell factor for the sensor being calibrated, found on the sensor data label.

FS = Full Scale conductivity value expressed in mS/cm.

R = Resistance value, in ohms, to set on the decade resistance box.

Example:

Calibrate an FT10-MT12 Sensor with a range of 0 - 5 mS/cm using a Foxboro calibration cable.

From the sensor data label, $Cf_{(\text{geom})} = 11.71 \text{ cm}^{-1}$.

From Formula above, $R = (11.71 \cdot 1000) / (5) = 2342 \text{ ohms}$.

Calibration Procedure

1. Remove the calibration connector cover.
2. Connect the Foxboro calibration cable assembly (BS807BD) to the calibration connection on the sensor.

Connect the other end of the cable to a decade resistance box as shown in Figure 7 and set to the (low end) resistance calculated above.

NOTE

At high conductivities, you may do a low end calibration at 0.0 $\mu\text{S}/\text{cm}$, 0.0 mS/cm or 0.0 S/cm with the calibration cable not connected to the decade resistance box.

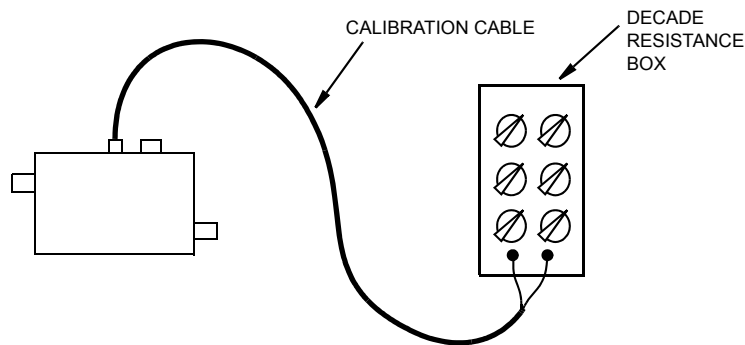

Figure 7. FT10 Calibration with Calibration Cable

3. Using the procedure in the appropriate instruction manual for the analyzer or transmitter being used (MI 611-224 for 875EC or MI 611-212 for 870ITEC), calibrate at the low end value. Also see MI 611-220, System Calibration Examples.
4. Set to the (full scale) resistance calculated above.
5. Using the procedure in the appropriate instruction manual for the analyzer or transmitter being used (MI 611-224 for 875EC or MI 611-212 for 870ITEC), calibrate at the full scale value. Also see MI 611-220, System Calibration Examples.
6. Disconnect the calibration cable from the sensor and replace the calibration connector cover.
7. Reinstall the sensor into the process if previously removed.

NOTE

The resistance in the calibration cable may introduce a zero shift in your calibration. Therefore at low conductivity, it is recommended that you proceed to perform a Solution 1 Pt Offset calibration at 0.0 $\mu\text{S}/\text{cm}$, 0.0 mS/cm or 0.0 S/cm , depending on the desired range (or at a nonzero low value, if desired).

Solution Calibration

This calibration may be performed using:

- ◆ NIST Standard KCl Solutions available from NIST or commercial suppliers (contact Global Customer Support for additional information),
- ◆ Equivalent solutions that may be prepared by the user, or
- ◆ A grab sample obtained by analyzing the process solution by means of an independent conductivity measurement.

— **NOTE** —

For highest accuracy, this calibration may be performed using NIST Standard KCl Solutions or equivalent solutions that may be prepared by the user.

Enter Data Into Analyzer or Transmitter

1. Check the model code for the sensor being calibrated. Note the tube/line size.

FT10-MT12F1T
└─ 08 = 1/2 inch
 12 = 3/4 inch
 16 = 1 inch

2. If using an 875EC Analyzer, select the appropriate sensor in the configuration menu.

Tube/Line Size	Select Sensor Type
Code 08 (1/2 inch)	FT10-08
Code 12 (3/4 inch)	FT10-12
Code 16 (1 inch)	FT10-16

— **NOTE** —

If using an 875EC Analyzer with firmware version earlier than 2.15, enter the appropriate electronic cell factor $C_{f(elec)}$ from Table 5 for the sensor being used in the configuration menu or contact Global Customer Support to request a firmware upgrade.

3. If using an 870ITEC Transmitter, enter the appropriate electronic cell factor $C_{f(elec)}$ from Table 5 for the sensor being used in the configuration menu.
4. Check the model code for the sensor being calibrated. Note the RTD type.

FT10-MT12F1T
└─ T = 100Ω, 3-wire
 R = 1000Ω, 3-wire

5. Enter the RTD type in the 875EC Analyzer or 870ITEC Transmitter using the appropriate configuration menu.
6. Refer to Table 6 to determine the minimum and maximum full scale conductivity range for the system being calibrated.

Enter the desired full scale conductivity range in the 870ITEC Transmitter or 875EC Analyzer using the appropriate configuration menu.

⚠ CAUTION

When calibrating analyzer (transmitter)/sensor systems using solutions, it is important to account for the effect of temperature in the procedure.

Calibration Procedure

1. Prepare a calibration solution having a known conductivity in the required measuring range.
2. Empty, clean and dry the sensor.
3. Connect the sensor to the analyzer or transmitter.
4. Using the procedure in the applicable instruction for the analyzer or transmitter being used (MI 611-224 for 875EC or MI 611-212 for 870ITEC), calibrate the low value at 0.0 $\mu\text{S}/\text{cm}$, 0.0 mS/cm or 0.0 S/cm , depending on the desired range (or at a nonzero low value, if desired). Also see MI 611-220, System Calibration Examples.
5. Fill the sensor with the appropriate calibrating solution or measure the conductivity of the solution in the sensor using an independent conductivity system. (Note effects of temperature on conductivity. Typically conductivity increases with temperature.)

— NOTE

Assure that the sensor is completely full. It is recommended that this be done with the sensor mounted in the vertical position as shown in Figure 2.

6. Using the procedure in the applicable instruction for the analyzer or transmitter being used (MI 611-224 for 875EC or MI 611-212 for 870ITEC), calibrate for the conductivity of the known solution. Also see MI 611-220, System Calibration Examples.

4. Troubleshooting and Maintenance

Troubleshooting

Table 7. Symptoms, Possible Causes, and Remedies

Symptom	Possible Cause	Remedy
Noisy signal	<ol style="list-style-type: none"> 1. Improper grounding. 2. Cavitation or bubbles entering sensor. 3. Wrong electrical cell factor. 4. Bad calibration 	<ol style="list-style-type: none"> 1. See “System Wiring” on page 18. 2. See “Sensor Mounting” on page 15 and/or adjust flow rate. 3. Use correct electrical cell factor. 4. Recalibrate.
No signal	<ol style="list-style-type: none"> 1. Loose connection in wiring to sensor. 2. Open Toroid. 3. Loose patch cord connector. 	<ol style="list-style-type: none"> 1. Fix connection. 2. Replace sensor. Tighten patch cord connector.
Reduced sensitivity	<ol style="list-style-type: none"> 1. One of drive toroids electrically open. 2. Calibrated full scale (FSC) too high. 3. Sensor not full of process liquid. 	<ol style="list-style-type: none"> 1. Replace sensor. 2. Use lower FSC or use multi-application feature. 3. Increase flow.
Temperature reads incorrectly	<ol style="list-style-type: none"> 1. Temperature setup incorrect. 2. Temperature not stabilized. 3. Short/open RTD. 4. Temperature not calibrated. 	<ol style="list-style-type: none"> 1. Check configuration of analyzer or transmitter. 2. Allow temperature to stabilize. 3. Replace sensor or contact Global Customer Support about remote RTD. 4. Calibrate temperature.
Accuracy	<ol style="list-style-type: none"> 1. Magnetization. 2. Installed before calibration. 	<ol style="list-style-type: none"> 1. Demagnetize (degauss) sensor. 2. Calibrate after installation.
Calibration appears incorrect	<ol style="list-style-type: none"> 1. Incorrect $Cf_{(geom)}$ used. 2. Incorrect calibration plug used. 3. Calibrated full scale (FSC) too high. 4. Incorrect unit of measurement used. 	<ol style="list-style-type: none"> 1. Use correct $Cf_{(geom)}$. 2. Use EP485N plug for correct FT10 model and conductivity value. 3. Use lower FSC or use multi-application feature. 4. Use correct unit.
Cannot reach high conductivity end of scale	<ol style="list-style-type: none"> 1. Wrong electrical cell factor. 	<ol style="list-style-type: none"> 1. Use correct electrical cell factor.

Maintenance

The FT10 Flow-Through Conductivity Sensor is a completely sealed unit, and therefore cannot be repaired. Any attempt to open the sensor voids the warranty.

Return Policy

In compliance with U.S. Federal OSHA Standard 29CFR1910.1200, process information must be reviewed prior to receiving authorization to return material. Please note that **No Product Exposed to Hydrofluoric Acid or Mercury Will Be Accepted for any reason.**

Warranty

A one-year workmanship warranty applies to FT10-MT Sensors.

The sensors are offered in many variations and wetted material configurations. These sensors are intended to service a myriad of applications in many diverse industries. While some recommendation can be provided for selection of wetted materials for any application, the final materials compatibility decision, and ultimate use of any sensor rests with the end-user. Warranty offered is for workmanship related items.

Index

B

Bench Calibration 21

C

Calibration 21

 Bench 21

 Solution 26

E

Electrical Safety Specifications 12

I

Identification 15

Installation 15

M

Maintenance 29

Model Code 13

Mounting 15

R

Reference Documents 9

S

Solution Calibration 26

Specifications 9

T

Troubleshooting 29

W

Wiring 18

ISSUE DATES

FEB 2007
OCT 2007
FEB 2016

Vertical lines to the right of text or illustrations indicate areas changed at last issue date.



Invensys Systems, Inc.
38 Neponset Avenue
Foxboro, MA 02035
United States of America
<http://www.fielddevices.foxboro.com>

Global Customer Support
Inside U.S.: 1-866-746-6477
Outside U.S.: 1-508-549-2424
Website: <http://support.ips.invensys.com>

Copyright 2007-2016 Invensys Systems, Inc.
All rights reserved.

Invensys and Foxboro are trademarks of Invensys Limited, its subsidiaries, and affiliates. All other trademarks are the property of their respective owners.

Invensys is now part of Schneider Electric.