

# 80 & 81 SERIES RESILIENT SEATED BUTTERFLY VALVES



**JFELLOW<sup>®</sup>**  
CONTROL S  
**JF**



## High Quality Valves

High quality valves that exceeds your highest expectations...



### JFLOW BUTTERFLY VALVES

Quality is designed into every JFLOW BUTTERFLY VALVE to meet the rigorous requirement of commercial & industrial applications.

JFLOW has been selling butterfly valves since 2001 for the OEM market and for distributors. JFLOW valves are manufactured under an ISO 9001:2008, ISO 14001: 2004, NSF 61, 372 & CE Pressure Equipment Directive (PED) Quality Assurance Program. All butterfly valve designs can be ordered as CE marked.

JFLOW valves are available with fully traceable Mill Test Certificate for both Body and Disc. Every JFLOW valves are 100% pressure tested & quality inspected. JFLOW valves are compliant to the Trade Agreements Act (FAR 52.225-5)

JFLOW has a complete offering of valves for the HVAC, chemical plant, water work, membrane plant, food & beverage, municipal, pulp & paper, steel mills, tank trucks, ship vessels and oil & gas industry.



# Contents

## BUTTERFLY VALVES



## RESILIENT SEATED VALVES

4 ~ 5	ADVANTAGES OF CARTRIDGE SEAT
6	RESILIENT SEATED BUTTERFLY VALVE FEATURES
7	PARTS & MATERIAL SELECTION : CARTRIDGE SEAT TYPE
8	80 SERIES: WAFER CARTRIDGE TYPE
9	81 SERIES: LUG CARTRIDGE TYPE
10 ~ 11	TORQUES REQUIRED TO OPERATE BUTTERFLY VALVES
12	OPERATING CHARACTERISTICS FOR SIZING
13	BUTTERFLY VALVE TOP FLANGE DIMENSION
14	MATERIAL SELECTION / HOW TO ORDER
15	LEVER
16	GEAR



## Why Jflow Cartridge seat are the better choice?

The cartridge seat is a unified, rigid component that is formed by bonding an elastomer to a hard, dense phenolic composite ring, which is inserted into the valve body. The phenolic backing keeps the elastomer from shifting during installation, reducing seat tearing and fatigue caused by bunching.

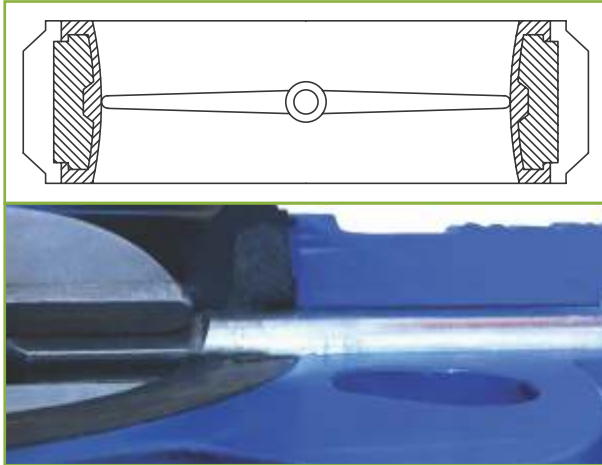

### Cartridge Type Seat (Phenolic Backed)

- Elastomer is supported by hard phenolic backing which eliminates seat shifting during installation.
- Seat to disc seal is independent of flange support and capable of full rated dead end service.
- Static seat design allows disc to sweep into seat for lower, more consistent torque.
- Smaller mass of elastomer minimizes seat swell.

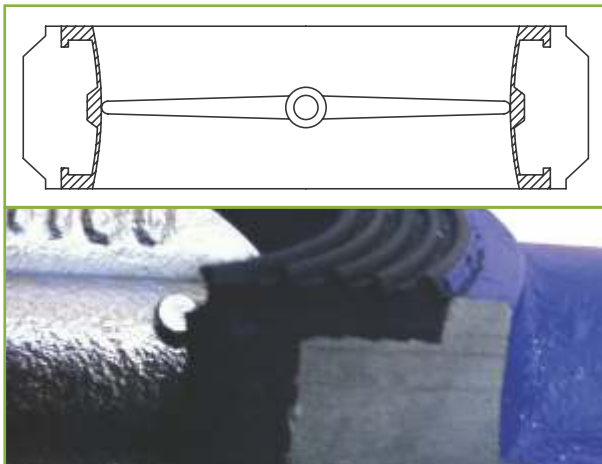

### Molded Type Seat (Vulcanized Design)

- Molded seat is bonded directly to the body of the valve through an injection molding process and seats are not replaceable.
- The elastomer is applied to inner diameter of the cast valve body without prior machining and difficult to produce consistent seat thickness to have consistent torque in valve operation.
- Molded seats resist deformation and dislocation during valve mounting, and they are capable of dead end or vacuum service.

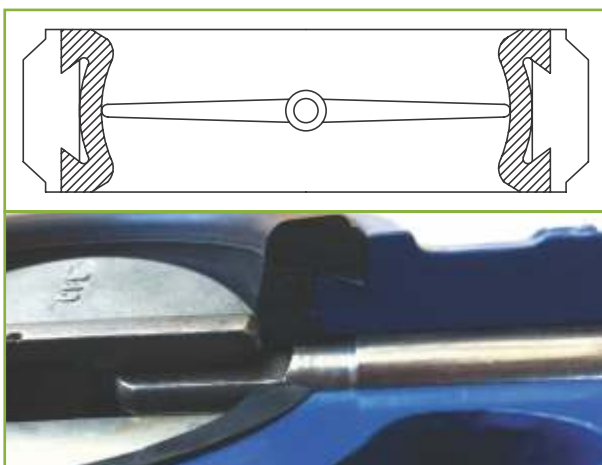

### Common Booted Type Seat (Dovetail Design)

- Dynamics of seat based on being installed between two flanges making seat subject to distortion during installation.
- Standard seat design is not rated for full pressure on dead end service.
- Disc is designed to push into seat causing distortion and inconsistent torque.
- Over abundance of elastomer exaggerates any swelling.

Jflow's Cartridge seats offer advantages unmatched by other seat types. The chart to the right compares features of the three different seat styles.

Feature	Cartridge Seat	Molded Seat	Booted Seat
Replaceable	YES	NO	YES
Consistent Torque	YES	NO	NO
Ideal for Vacuum Service	YES	YES	NO
Dead End Service Capable (Lug only)	YES	YES	NO
Deformation Resistant	YES	YES	NO
Flange Type Independent	YES	YES	NO

## Cartridge Seated BFV Applications

Butterfly valves with cartridge style seats can mount in a variety of flange configurations because the seat resists deformation and is mostly independent of unique mounting conditions.

In highly abrasive applications where valves need to be replaced on a regular basis, the cartridge seat could simply be replaced rather than the entire valve. Cartridge seated valves are capable of dead end service. Furthermore, unlike booted or dovetail seats, cartridge seats are rated and more suitably designed to operate in a system that requires vacuum service. The cartridge seat unlocks the full potential of resilient-seated butterfly valves and provides competitive solutions for the fluid flow industry.

The resilient seat butterfly design incorporates a disc interference with the seat at the top and bottom hub area which act as the primary seal. If the primary seal ever fails, which could be due to a variety of reasons such as abrasives damaging the seat, incorrect installation, or wear itself after years of high cycles, the process media could migrate its way up through the stem.

The end result is that the media such as water could make its way into direct coupled actuators, damaging the actuator and solenoid valve. If systems are using remote solenoid valve panels the fluid from one leaking stem could potentially find its way back into the solenoid manifold, migrating to other actuators and damaging those.

To prevent such an occurrence from happening, Jflow has included "Leak Path" channels into our valve design. This would mitigate chances of the process media making its way into direct coupled actuators and provide easy identification that the primary seal has been compromised and should be inspected.



## Elastomer General Table

### **EPDM**

#### **Ethylene - Propylene Terpolymer**

Hydrocarbon-elastomer with good resistance to cold and hot water, low pressure steam, many solvents some acids and alkalis. Not recommended for Hydrocarbons, Oil & fats  
Operating range : -30°C to +110°C

### **HIGH EPDM**

High Temperature EPDM  
Operating range : -30°C to +130°C

### **WHITE EPDM**

Especially suitable in food product services.  
Operating range : -10°C to +1°C

### **TEFLON**

on nitrile: Unique chemical resistance.  
Operating range : -10°C to +110°C

### **BUNA- N (NBR)**

#### **Copolymer of Butadiene and high Acrylonitrile**

Nitrile elastomer for general purpose applications. High tensile strength, low compression, good resistance to ageing. It is very resistant to water, air, non-aromatic oils, alcohol and abrasive media.  
Operation range : -20°C to +90°C

### **VITON**

#### **Fluorocarbon Polymer**

High chemical resistance particularly at elevated temperatures service. Good service in gasoline, fuels, oils, solvents, mineral acids and aromatic hydrocarbons. Not recommended for steam  
Operating range : -10°C to +135°C

## Resilient Seated Butterfly Valve

**81 Series: LUG , CARTRIDGE SEAT TYPE**

**80 Series: WAFER, CARTRIDGE SEAT TYPE**

Size : Cartridge design seat type : 2"~24"

Type : Wafer , Lug

Pressure Rating : Class 125/150

Body Material : Cast Iron, Ductile Iron and Stainless Steel.

Seat Type : Cartridge Type

Operation : Lever , Gear , Actuators

Drilling : ANSI 125/150, JIS 10K, DIN PN 10/16

- One – piece body construction of Ductile Iron, Cast Iron or Stainless Steel design complies with API 609, MSS SP 67, and ISO 5752.
- ISO 5211 mounting pad with square or key type stem shaft permits direct mount actuation for both Manual (Lever & gear), pneumatic and electric operations.
- Teflon stem bushing to assure long life even during extended period of activity. Lowers operating torque for easy manual operation and maximize shaft support.
- High strength two-piece stem eliminates taper pins or disc screws which often fail prematurely through abrasion, corrosion or fatigue.
- All disc castings are spherically machined & polished for extended seat life & bubble tight shut off.
- Seat type available in both encapsulated phenolic or Aluminum backed Cartridge seat. Cartridge design seat permits easy change without special tools.
- Reduced Disc option for lower pressure applications, requiring lower torque and smaller actuators.
- Conform to API 598 and MSS SP 61. Shell tested to 150% and seat tested to 110% of maximum working pressure.  
Every ST&H valve is pressure tested & Quality Inspected.
- Full Rated Disc, Lug body valves are rated for 150 PSI in dead end service.
- Valve Rating:
  - Top flange mounting pad: ISO 5211
  - Basic Design: API 609, MSS-SP-67, BS 5155, ISO 5752, DIN 3202
  - Shell/Seat Test: API 598, MSS-SP-61
  - Shell Test : DI (400 psig), CI (350 psig)
  - Closure Test : 165 psig
  - Full Disc Max. Pressure Shutoff Rating : 150 PSI
  - Reduced Disc Max Pressure Shutoff Pressure Rating : 50 PSI



## Cartridge Type Butterfly Valve Parts

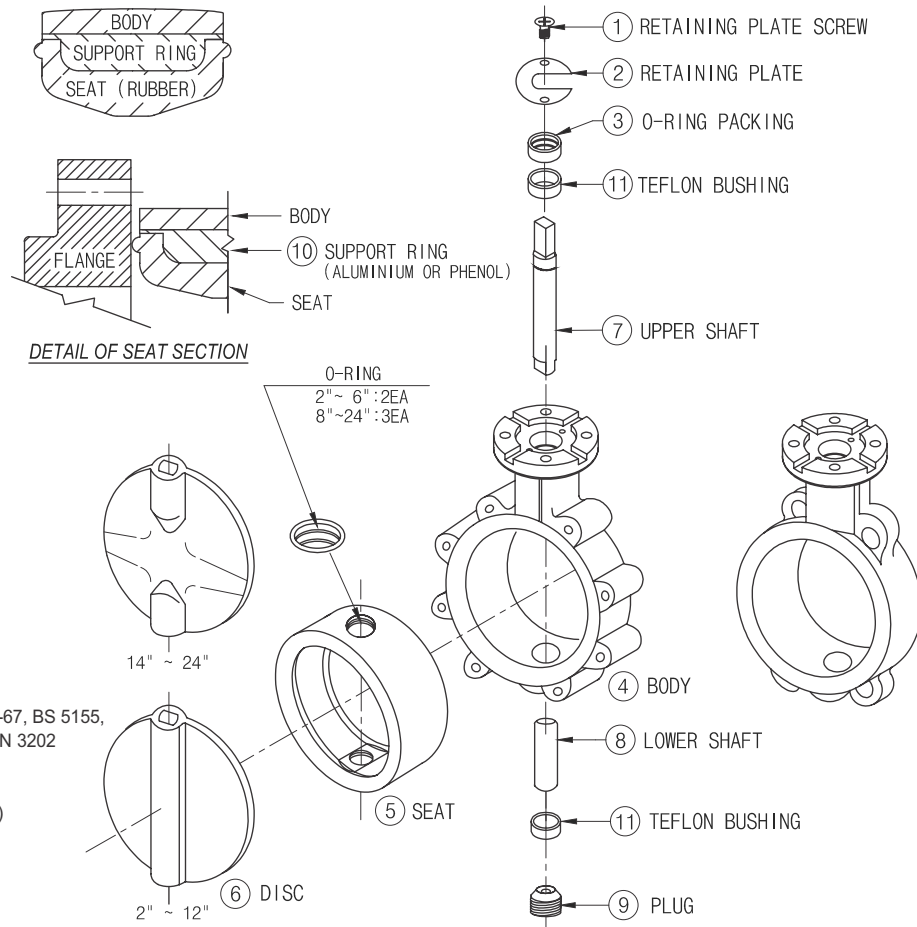

- NOTE :
1. BASIC DESIGN :  
 DIMENSION : API 609, MSS-SP-67, BS 5155,  
 ISO5752, DIN 3202  
 TOP FLANGE : ISO 5211
  2. TESTING : API 598, MSS-SP-61  
 SHELL : DI (400 psig), CI (350 psig)  
 CLOSURE : 150 psig

### Standard Material

NO	DESCRIPTION	MATERIAL	CODE NO.	STANDARD	REMARKS
1	RETAINING PLATE SCREW	CARBON STEEL/ STAINLESS STEEL	304	ASTM A283D-A36	GALVANIZED
2	RETAINING PLATE	CARBON STEEL/ STAINLESS STEEL	316	ASTM A283D-A36	GALVANIZED
3	O-RING PACKING	EPDM or NBR		ASTM D2000	
4	BODY	CAST IRON	GG25	ASTM A126/ EN1561	
		DUCTILE IRON	GGG40	ASTM A536/ DIN1693	
		STAINLESS STEEL	CF8M	ASTM A351	
5	SEAT	EPDM		ASTM D2000	WORKING TEMPERATURE -30 °C ~ +110 °C
		BUNA-N (NBR)		ASTM D2000	-20 °C ~ +90 °C
		WHITE EPDM		ASTM D2000	-30 °C ~ +110 °C
		VITON		ASTM D2000	-10 °C ~ +160 °C
		HIGH TEMPERATURE EPDM		ASTM D2000	-30 °C ~ +130 °C
		TEFLON (PTFE)		PTFE	-40 °C ~ +250 °C
6	DISC	DUCTILE IRON	GGG40	ASTM A536/DIN1693	CHROME/ NICKEL PLATED/ NYLON 11 COATING
		STAINLESS STEEL	CF8M	ASTM A351	
		ALUMINIUM BRONZE		ASTM B148	
7	UPPER STEM	STAINLESS STEEL	SS 304	ASTM	
	SS 316		A479		
8	LOWER STEM		SS 410	A 276	
	SS 420		A 582		
9	PLUG	CARBON STEEL/ STAINLESS STEEL	316	ASTM A283D-A36	
10	SUPPORT RING	PHENOL		ASTM D2000	(2" ~ 14")
		ALUMINIUM		ASTM B275	(16" ~ 24")
11	TEFLON BUSHING	TEFLON		PTFE	

Alternative Material available upon Special Request

# Model : 80 Series Cartridge Seat Type

## Wafer Type, Common Drilled ANSI 150LBS, DIN PN10, PN16, JIS10K

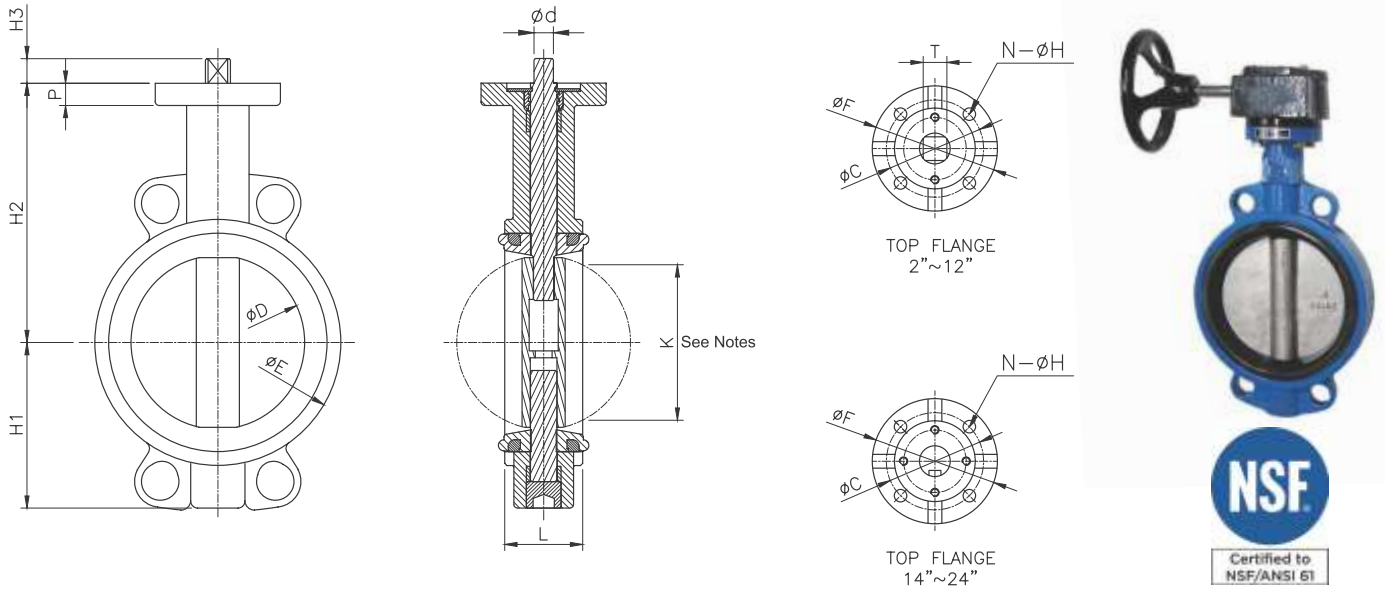

### Dimensions

(unit : mm)

SIZE	TOP FLANGE & STEM									OUT LINE DIMENSION					
	mm	Ød	P	ØC	N	ØH	T	ØF	H3	ISO 5211	L	ØD	H1	H2	ØE
50A	14.0	14	70	4	9	11	90	15.2	F07	43	52.0	70.4	128.4	93	29.2
65A	14.0	14	70	4	9	11	90	15.2	F07	46	67.0	75.1	136.0	108	48.7
80A	14.0	14	70	4	9	11	90	15.2	F07	46	80.0	93.2	143.2	126	65.5
100A	16.0	16	70	4	9	14	90	17.7	F07	52	100.0	106.2	162.7	150	85.4
125A	18.0	16	70	4	9	14	90	17.7	F07	56	125.0	119.1	186.5	177	111.8
150A	18.0	16	70	4	9	14	90	17.7	F07	56	150.5	139.2	202.7	208	139.7
200A	22.0	17	70	4	9	17	90	20.5	F07	60	196.5	166.3	237.2	259	187.2
250A	25.4	20	102	4	11	22	125	20.5	F10	68	247.0	199.6	282.6	317	237.5
300A	28.0	20	102	4	11	22	125	24.1	F10	78	295.5	240.6	311.6	371	285.0
350A	28.0	20	102	4	12		125	70.0	F10	78	330.0	264.5	345.5	415.1	320.4
400A	32.0	23	140	4	18		175	80.0	F14	102	379.0	298.5	349.5	474.7	365.0
450A	38.0	23	140	4	18		175	80.0	F14	114	437.0	354.5	400.0	526.5	421.9
500A	45.0	23	165	4	22		210	90.0	F16	127	490.0	384.5	440.0	588.5	473.3
600A	55.0	23	165	4	22		210	95.0	F16	154	574.5	444.5	510.0	706.1	553.5

(unit : inch)

SIZE	TOP FLANGE & STEM									OUT LINE DIMENSION					
	inch	Ød	P	ØC	N	ØH	T	ØF	H3	ISO 5211	L	ØD	H1	H2	ØE
2"	0.55	0.55	2.76	4	0.35	0.43	3.54	0.60	F07	1.69	2.05	2.77	5.06	3.66	1.15
2 1/2"	0.55	0.55	2.76	4	0.35	0.43	3.54	0.60	F07	1.81	2.64	2.95	5.36	4.25	1.92
3"	0.55	0.55	2.76	4	0.35	0.43	3.54	0.60	F07	1.81	3.15	3.67	5.64	4.96	2.58
4"	0.63	0.63	2.76	4	0.35	0.55	3.54	0.70	F07	2.05	3.94	4.18	6.41	5.91	3.36
5"	0.71	0.63	2.76	4	0.35	0.55	3.54	0.70	F07	2.20	4.92	4.69	7.34	6.97	4.40
6"	0.71	0.63	2.76	4	0.35	0.55	3.54	0.70	F07	2.20	5.93	5.48	7.98	8.19	5.50
8"	0.87	0.67	2.76	4	0.35	0.67	3.54	0.81	F07	2.36	7.74	6.55	9.34	10.2	7.37
10"	1.00	0.79	4.02	4	0.43	0.87	4.92	0.81	F10	2.68	9.72	7.86	11.13	12.48	9.35
12"	1.10	0.79	4.02	4	0.43	0.87	4.92	0.95	F10	3.07	11.63	9.47	12.27	14.61	11.22
14"	1.10	0.79	4.02	4	0.47		4.92	2.76	F10	3.07	12.99	10.41	13.60	16.34	12.61
16"	1.26	0.91	5.51	4	0.71		6.89	3.15	F14	4.02	14.92	11.75	13.76	18.69	14.37
18"	1.50	0.91	5.51	4	0.71		6.89	3.15	F14	4.49	17.20	13.96	15.75	20.73	16.61
20"	1.77	0.91	6.50	4	0.87		8.27	3.54	F16	5.00	19.29	15.14	17.32	23.17	18.63
24"	2.17	0.91	6.50	4	0.87		8.27	3.74	F16	6.06	22.62	17.50	20.08	27.8	21.79

Note: Alternative Top Flange ISO 5211 drilling available on selected sizes, Please refer to Top Flange Dimension on page 14.

"K" dimension shall be taken into account for adequate internal pipe clearance



Model : 81 Series

Lug - Cartridge Type, ANSI 150LBS, DIN PN10, PN16, JIS10K

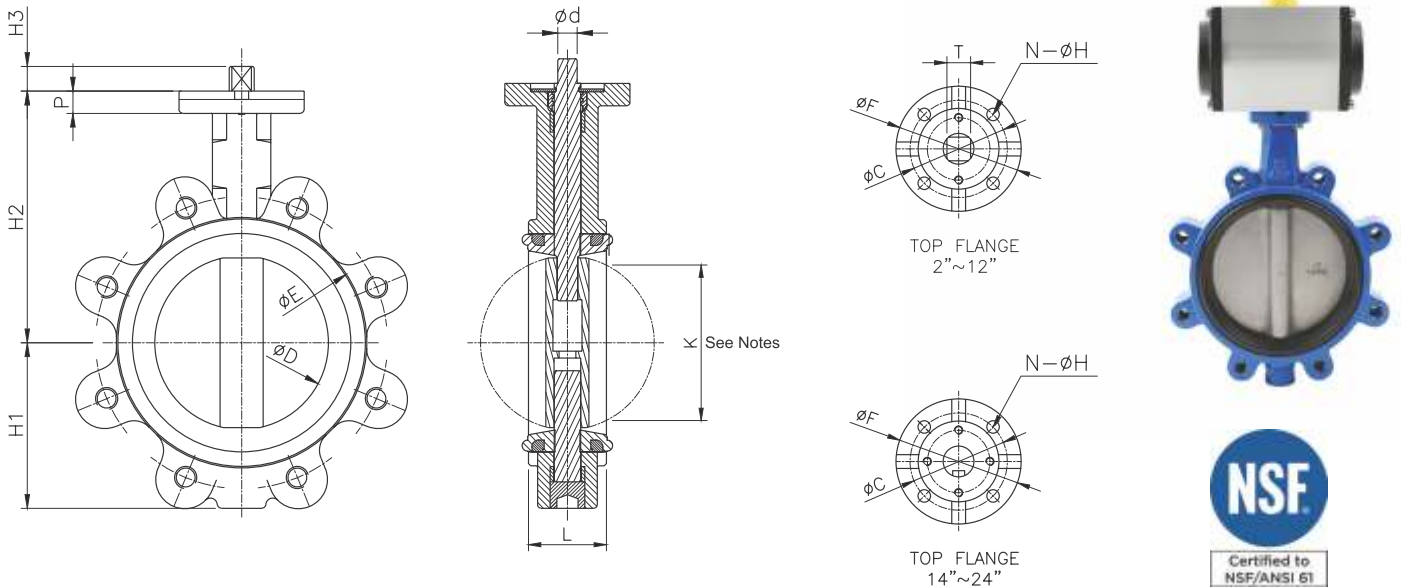

## Dimension

(unit : mm)

SIZE	TOP FLANGE & STEM									OUT LINE DIMENSION					
	mm	Ød	P	ØC	N	ØH	T	ØF	H3	ISO 5211	L	ØD	H1	H2	ØE
50A	14.0	14	70	4	9	11	90	15.2	F07	43	52.0	70.4	125.4	93	29.2
65A	14.0	14	70	4	9	11	90	15.2	F07	46	67.0	75.0	132.0	108	48.7
80A	14.0	14	70	4	9	11	90	15.2	F07	46	80.0	93.2	154.2	122	65.5
100A	16.0	16	70	4	9	14	90	17.7	F07	52	100.0	106.2	166.2	150	85.4
125A	18.0	16	70	4	9	14	90	17.7	F07	56	125.0	119.0	181.0	180	111.8
150A	18.0	16	70	4	9	14	90	17.7	F07	56	150.5	143.0	203.0	208	139.7
200A	22.0	17	70	4	9	17	90	20.5	F07	60	196.5	165.2	235.2	259	187.2
250A	25.4	20	102	4	11	22	125	20.5	F10	68	247.0	199.6	266.6	318	237.5
300A	28.0	20	102	4	11	22	125	24.1	F10	78	295.5	240.6	308.6	371	285.0
350A	28.0	20	102	4	12		125	70.0	F10	78	330.0	264.5	345.5	415.1	320.4
400A	32.0	23	140	4	18		175	80.0	F14	102	379.0	299.0	349.5	474.7	365.0
450A	38.0	23	140	4	18		175	80.0	F14	114	437.0	350.0	400.0	526.5	421.9
500A	45.0	23	165	4	22		210	90.0	F16	127	490.0	380.0	440.0	588.5	473.3
600A	55.0	23	165	4	22		210	95.0	F16	154	574.5	440.0	510.0	706.1	553.5

(unit : inch)

SIZE	TOP FLANGE & STEM									OUT LINE DIMENSION					
	inch	Ød	P	ØC	N	ØH	T	ØF	H3	ISO 5211	L	ØD	H1	H2	ØE
2"	0.55	0.55	2.76	4	0.35	0.43	3.54	0.60	F07	1.69	2.05	2.77	4.94	3.66	1.15
2 1/2"	0.55	0.55	2.76	4	0.35	0.43	3.54	0.60	F07	1.81	2.64	2.95	5.20	4.25	1.92
3"	0.55	0.55	2.76	4	0.35	0.43	3.54	0.60	F07	1.81	3.15	3.67	6.07	4.8	2.58
4"	0.63	0.63	2.76	4	0.35	0.55	3.54	0.70	F07	2.05	3.94	4.18	6.54	5.91	3.36
5"	0.71	0.63	2.76	4	0.35	0.55	3.54	0.70	F07	2.20	4.92	4.69	7.13	7.09	4.40
6"	0.71	0.63	2.76	4	0.35	0.55	3.54	0.70	F07	2.20	5.93	5.63	7.99	8.19	5.50
8"	0.87	0.67	2.76	4	0.35	0.67	3.54	0.81	F07	2.36	7.74	6.51	9.26	10.2	7.37
10"	1.00	0.79	4.02	4	0.43	0.87	4.92	0.81	F10	2.68	9.72	7.86	10.50	12.52	9.35
12"	1.10	0.79	4.02	4	0.43	0.87	4.92	0.95	F10	3.07	11.63	9.47	12.15	14.61	11.22
14"	1.10	0.79	4.02	4	0.47		4.92	2.76	F10	3.07	12.99	10.41	13.60	16.34	12.61
16"	1.26	0.91	5.51	4	0.71		6.89	3.15	F14	4.02	14.92	11.75	13.76	18.69	14.37
18"	1.50	0.91	5.51	4	0.71		6.89	3.15	F14	4.49	17.20	13.78	15.75	20.73	16.61
20"	1.77	0.91	6.50	4	0.87		8.27	3.54	F16	5.00	19.29	14.96	17.32	23.17	18.63
24"	2.17	0.91	6.50	4	0.87		8.27	3.74	F16	6.06	22.62	17.32	20.08	27.8	21.79

Note : Alternative Top Flange ISO 5211 drilling available on selected sizes, Please refer to Top Flange Dimension on page 14.

"K" dimension shall be taken into account for adequate internal pipe clearance

## Torques Required to Operate Jflow Butterfly Valves

### STANDARD BUTTERFLY VALVE TORQUE

SEAT DESIGN : CARTRIDGE TYPE

SEAT : EPDM, BUNA-N

(Torque Unit : lbf.inch)

DISC		CF8M			
TYPE		STANDARD			UNDERCUT
PRESSURE	SIZE	50PSI	100PSI	150PSI	50PSI
2"	50A	142	255	367	116
2 1/2"	65A	254	311	367	116
3"	80A	254	311	367	116
4"	100A	367	367	367	231
5"	125A	593	593	593	204
6"	150A	621	723	824	328
8"	200A	1,039	1,186	1,332	514
10"	250A	2,675	2,974	3,273	1,381
12"	300A	3,386	3,725	4,063	1,496
14"	350A	4,602	5,839	7,076	1,956
16"	400A	5,178	10,563	15,948	3,452
18"	450A	8,583	13,267	17,950	5,178
20"	500A	11,621	15,608	19,595	8,054
24"	600A	16,338	32,223	48,107	13,806

(Torque Unit : N/m)

DISC		CF8M			
TYPE		STANDARD			UNDERCUT
PRESSURE	SIZE	50PSI	100PSI	150PSI	50PSI
2"	50A	16	29	41	13
2 1/2"	65A	29	35	41	13
3"	80A	29	35	41	13
4"	100A	41	41	41	26
5"	125A	67	67	67	23
6"	150A	70	82	93	37
8"	200A	117	134	150	58
10"	250A	302	336	370	156
12"	300A	383	421	459	169
14"	350A	520	660	799	221
16"	400A	585	1,194	1,802	390
18"	450A	970	1499	2,028	585
20"	500A	1,313	1,764	2,214	910
24"	600A	1,846	3,641	5,435	1,560

## Torques Required to Operate Jflow Butterfly Valves

### TEFLON SEAT

ACTUAL TORQUE : N.m			TORQUE : lbf.inchs		
SIZE		11bar	SIZE		165psi
50A	2"	19	50A	2"	13
65A	2.5"	25	65A	2.5"	19
80A	3"	51	80A	3"	38
100A	4"	51	100A	4"	38
125A	5"	103	125A	5"	808
150A	6"	145	150A	6"	808
200A	8"	281	200A	8"	1,395
250A	10"	358	250A	10"	3,858
300A	12"	637	300A	12"	47,070

• NOTE :

All torques shown on the chart were derived from test data using water at 5°C.  
 For torque using dry gases, multiply these numbers by 1.6  
 Above table has additional 30% safety factor to average net torque

The torques listed are applicable to sea water, lubricating type of hydro carbons and most media at temperature 0~82°C(32~180 °F).  
 The operating speed of the actuator must be considered in order to avoid water hammer when the valve is closed in junction with Liquid.

### The factors which affect the torque required to operate Butterfly Valves

- Valve Diameter
- Shaft Diameter
- Bearing Friction Coefficient
- Type of Seat Material
- Shut off Pressure
- Velocity
- Shape of Disc
- System Head Characteristics
- Piping Arrangement

Actuator torques can be calculated using the following formulas.

- $T_a = T_b + T_s + T_h = 1.2T_b \pm T_d$
- $T_s = C_s D^2$
- $T_b = 4.17 D^2 d f P$
- $T_d = C_t D^3 P$
- $T_h = 3.06 D^4$

$$V = C_f \sqrt{P} = \frac{Q}{0.785 D^2}$$

- Ta : The required actuator torque(lb-ft)
- Ts : Seating or unseating torque(lb-ft)
- Td : Dynamic torque(lb-ft)
- Th : Hydrostatic torque(lb-ft)
- Q : Flow (cubic for per second)
- V : Velocity (feet per second)
- D : Diameter of valve (feet)
- d : Diameter of Shaft (inch)
- P : Pressure drop across valve(psi)
- Cs : Coefficient of Seating or unseating torque
- Ct : Coefficient of dynamic torque
- Cf : Coefficient of flow
- f : Bearing friction Coefficient

## Operating Characteristics for Sizing

• The Size of Butterfly Valve used for control purpose should be calculated on the basis of the operating characteristics. In order to achieve optimum control, the flow coefficient (Cv, Kv) below need to be considered.

• Flow Coefficient for Jflow corporation Butterfly Valves.

SIZE		DISC OPENING															
		20°		30°		40°		50°		60°		70°		80°		90°	
		Kv	Cv	Kv	Cv	Kv	Cv	Kv	Cv	Kv	Cv	Kv	Cv	Kv	Cv	Kv	Cv
40	1 1/2"	3	3	4	5	10	11	16	18	22	26	39	45	60	70	69	80
50	2"	7	8	8	9	16	18	24	28	48	55	62	72	95	110	116	135
65	2 1/2"	9	10	13	15	23	27	38	44	73	85	95	110	145	168	181	210
80	3"	13	15	20	23	34	39	56	65	112	130	142	165	216	250	267	310
100	4"	23	27	35	41	61	71	99	115	198	230	259	300	401	465	466	540
125	5"	50	58	74	86	129	150	211	245	414	480	526	610	845	980	948	1,100
150	6"	83	96	121	140	211	245	345	400	677	785	871	1,010	1,392	1,615	1,647	1,910
200	8"	142	165	211	245	354	410	591	685	1,099	1,275	1,478	1,715	2,302	2,670	2,746	3,185
250	10"	220	255	328	380	560	650	974	1,130	1,810	2,100	2,328	2,700	3,664	4,250	4,224	4,900
300	12"	319	370	466	540	819	950	1,353	1,570	2,629	3,050	3,405	3,950	5,129	5,950	6,336	7,350
350	14"	388	450	647	750	1,120	1,300	1,905	2,210	3,517	4,080	4,836	5,610	6,964	8,078	9,665	11,200
400	16"	552	640	776	900	1,483	1,720	2,405	2,790	4,310	5,000	6,336	7,650	9,284	10,770	11,121	12,900
450	18"	630	730	1,078	1,250	1,978	2,295	3,190	3,700	6,078	7,050	7,914	9,180	11,983	13,900	15,086	17,500
500	20"	785	910	1,375	1,595	2,457	2,850	3,991	4,630	7,414	8,600	9,914	11,500	15,121	17,540	19,310	22,400
600	24"	1,078	1,250	1,974	2,290	3,448	4,000	5,250	6,090	10,776	12,500	14,224	16,500	20,336	23,590	24,397	28,300

• Cv is in imperial units, the water flow in U.S. gallons per minute which passes through the valve giving a pressure drop of 1 PSI at a temperature of 68°F

In metric units the same coefficient is called Kv and correspond to the flow rate in m3/h passing through the valve giving a pressure drop of 1 bar at a temperature of 20°C

The approximate corresponding formulas are :

$$Q = Cv \cdot \sqrt{\frac{\Delta p \cdot 62.4}{D}}$$

where :

Q = valve flow rate in gpm (USGPM)

$\Delta p$  = pounds per square inch (psi) pressure drop through the valve

62.4 = conversion factor for fluids computed in relation to water

D = pounds per cu.ft (pct) fluid density

$$Q = Kv \cdot \sqrt{\frac{\Delta p \cdot 1000}{D}}$$

where :

Q = valve flow rate in m3/h

$\Delta p$  = pressure drop through the valve in bar

1000 = conversion factor for fluids computed in relation to water.

D = Kg/m<sup>3</sup> fluid density

The relation between Cv and Kv, expressed in the above mentioned unit of measure is as follows ;

$$Cv = 1.16Kv$$

## Butterfly Valve Top Flange Dimension

SIZE 2"~12"

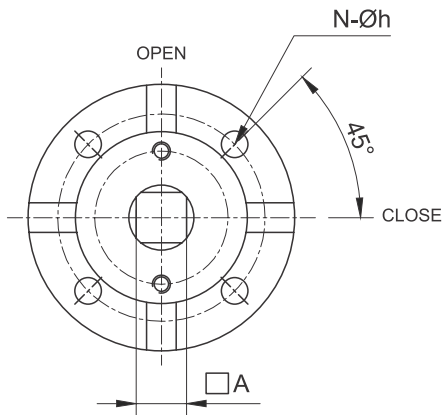

SIZE 14"~24"

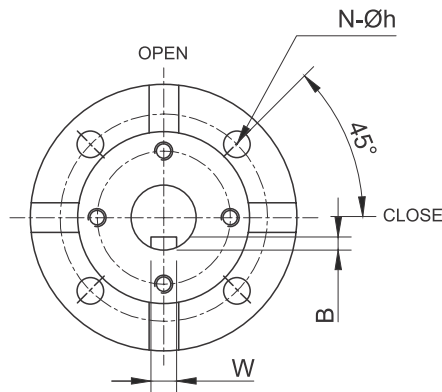

Square Stem type

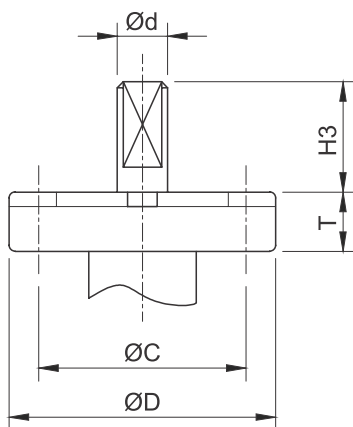

Key Stem type

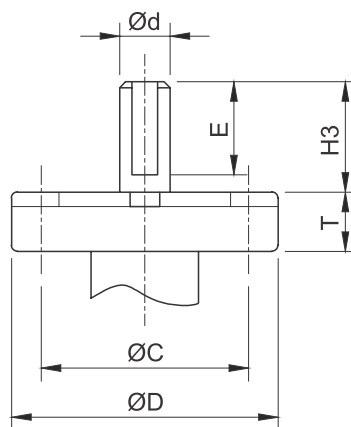

### Dimensions

(unit : mm)

SIZE		Ød	T	ØC	N	Øh	A	ØD	B	W	H3	E	ISO 5211
inch	mm												
2"	50	14.0	14	70	4	9	11	90	-	-	15.2	-	F07
2 1/2"	65	14.0	14	70	4	9	11	90	-	-	15.2	-	F07
3"	80	14.0	14	70	4	9	11	90	-	-	15.2	-	F07
4"	100	16.0	16	70	4	9	14	90	-	-	17.7	-	F07
5"	125	18.0	16	70	4	9	14	90	-	-	17.7	-	F07
6"	150	18.0	16	70	4	9	14	90	-	-	19.0	-	F07
8"	200	22.0	17	70	4	9	17	90	-	-	20.5	-	F07
10"	250	25.4	20	102	4	11	22	125	-	-	20.5	-	F10
12"	300	28.0	20	102	4	11	22	125	-	-	24.1	-	F10
14"	350	28.0	20	102	4	12	-	125	5	10	70.0	60	F10
16"	400	32.0	23	140	4	18	-	175	5	10	88.5	70	F12 / F14
18"	450	38.0	23	140	4	18	-	175	5	12	88.5	70	F12 / F14
20"	500	45.0	23	165	4	22	-	210	5	12	88.5	70	F12 / F14 / F16
24"	600	55.0	23	165	4	22	-	210	5	14	93.5	70	F16

Special Top Flange Design is available upon request

## Model : Lever

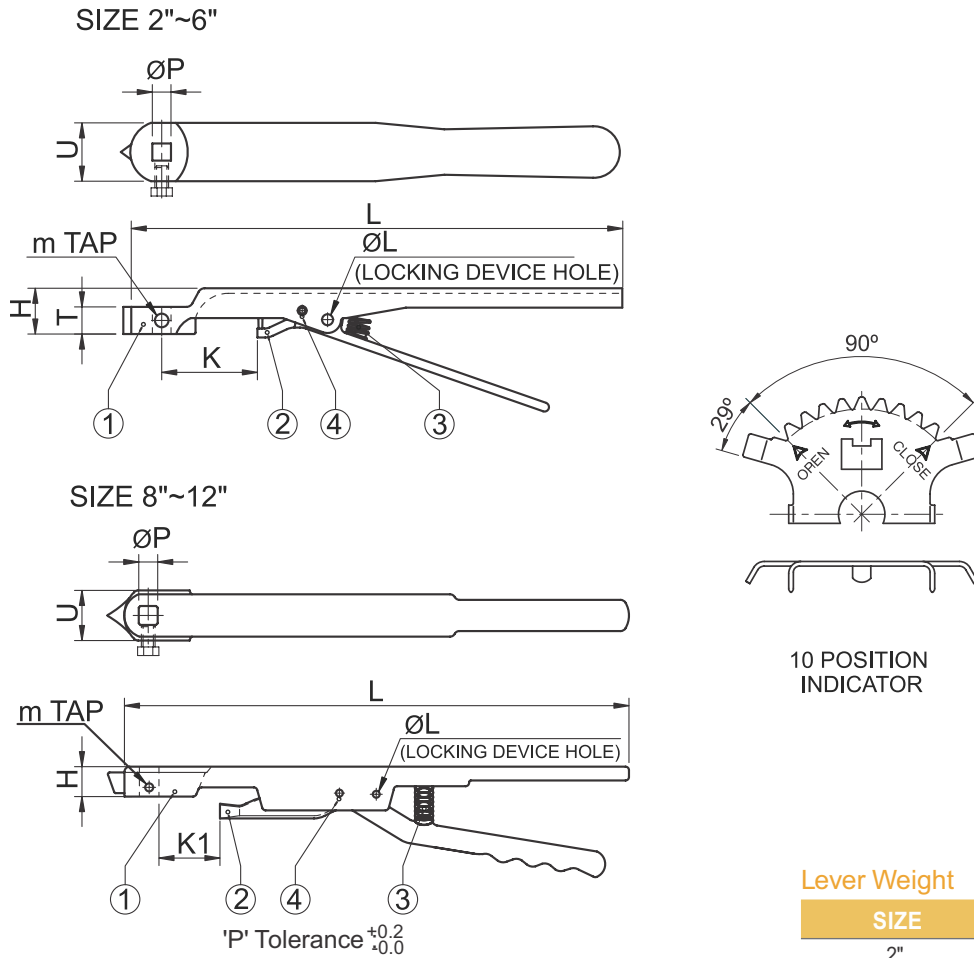

### STANDARD MATERIAL

NO.	DESCRIPTION	MATERIAL
1	Lever	Malleable Iron or Stainless Steel
2	Aux Lever	Malleable Iron or Stainless Steel
3	Spring	Steel or SS 304
4	Pin	Steel or SS 410

### Lever Weight

SIZE	KG
2"	0.50
2 1/2"	0.50
3"	0.50
4"	0.60
5"	0.60
6"	0.60
8"	1.85
10"	1.85
12"	1.85

### FOR STANDARD BUTTERFLY VALVE (unit : mm)

	P	T	L	m	U	H	K	K1	ØL
50	11	16	288.7	M8	34	27	53		7.5
65	11	16	288.7	M8	34	27	53		7.5
80	11	16	288.7	M8	34	27	53		7.5
100	14	18	288.7	M8	34	27	53		7.5
125	14	18	288.7	M8	34	27	53		7.5
150	14	18	288.7	M8	34	27	53		7.5
200	17		415.0	M10	45	26		42	7.5
250	22		415.0	M8	45	26		53	7.5
300	22		415.0	M8	45	26		53	7.5

(unit : inch)

	P	T	L	m	U	H	K	K1	ØL
2	0.43	0.63	11.37	M8	1.34	1.06	2.09		0.3
2.5	0.43		11.37	M8	1.34	1.06	2.09		0.3
3	0.43		11.37	M8	1.34	1.06	2.09		0.3
4	0.55		11.37	M8	1.34	1.06	2.09		0.3
5	0.55		11.37	M8	1.34	1.06	2.09		0.3
6	0.55	0.71	11.37	M8	1.34	1.06	2.09		0.3
8	0.67		16.34	M10	1.77	1.02		1.65	0.3
10	0.87		16.34	M8	1.77	1.02		2.09	0.3
12	0.87		16.34	M8	1.77	1.02		2.09	

Model : Gear

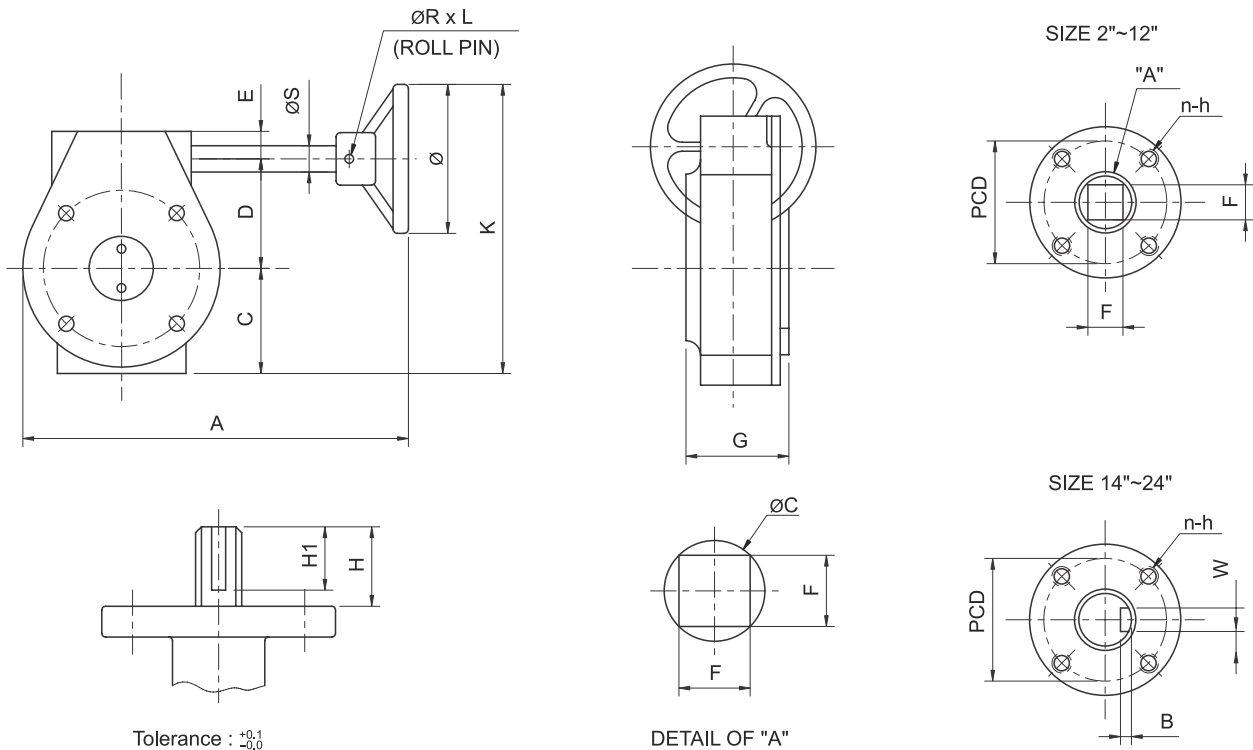

Dimensions

(unit : mm)

	RATIO	A	L	G	C	D	E	K	Ø	n-h	PCD	B	W	H	F	ØC	H1	ØS	ØRxL	Weight (lbs)
2	24:1	212	158	72	54	45	28	171	147	4-M8	70			15.2	11	14.0		16	5.2x40	3.40
2.5	24:1	212	158	72	54	45	28	171	147	4-M8	70			15.2	11	14.0		16	5.2x40	3.40
3	24:1	212	158	72	54	45	28	171	147	4-M8	70			15.2	11	14.0		16	5.2x40	3.40
4	24:1	212	158	72	54	45	28	171	147	4-M8	70			17.7	14	16.0		16	5.2x40	3.46
5	24:1	212	158	72	54	45	28	171	147	4-M8	70			17.7	14	18.0		16	5.2x40	3.46
6	24:1	212	158	72	54	45	28	171	147	4-M8	70			17.7	14	18.0		16	5.2x40	3.62
8	30:1	279	205	72	73	66	31	289	300	4-M8	70			20.5	17	22.0		19	6.4x50	6.70
10	30:1	279	205	72	76	66	34	292	300	4-M10	102			20.5	22	25.4		19	6.4x50	7.18
12	50:1	284	206	82	81	80	33	310	300	4-M10	102			24.1	22	28.0		19	6.4x50	9.58
14	50:1	284	206	78	88	79	35	316	300	4-M10	102	5	10	71.5		28.0	60	19	6.4x50	9.44
16	50:1	284	206	78	88	79	35	316	300	4-M16	140	5	10	80.0		32.0	60	19	6.4x50	10.34
18	50:1	284	206	81	88	79	35	359	385	4-M16	140	5	12	80.0		38.0	60	19	6.4x50	10.62
20	80:1	385	268	114	127	120	37	439	385	4-M20	165	5	12	90.0		45.0	70	25	8.4x51	23.54
24	80:1	385	268	114	127	120	37	439	385	4-M20	165	5	14	95.0		55.0	70	25	8.4x51	23.54

(unit : inch)

	RATIO	A	L	G	C	D	E	K	Ø	n-h	PCD	B	W	H	F	ØC	H1	ØS	ØRxL	Weight (lbs)
2	24:1	8.35	6.22	2.83	2.13	1.77	1.10	6.71	5.79	4-M8	2.76			0.60	0.43	0.55		0.63	0.2x1.57	7.50
2.5	24:1	8.35	6.22	2.83	2.13	1.77	1.10	6.71	5.79	4-M8	2.76			0.60	0.43	0.55		0.63	0.2x1.57	7.50
3	24:1	8.35	6.22	2.83	2.13	1.77	1.10	6.71	5.79	4-M8	2.76			0.60	0.43	0.55		0.63	0.2x1.57	7.50
4	24:1	8.35	6.22	2.83	2.13	1.77	1.10	6.71	5.79	4-M8	2.76			0.70	0.55	0.63		0.63	0.2x1.57	7.63
5	24:1	8.35	6.22	2.83	2.13	1.77	1.10	6.71	5.79	4-M8	2.76			0.70	0.55	0.71		0.63	0.2x1.57	7.63
6	24:1	8.35	6.22	2.83	2.13	1.77	1.10	6.71	5.79	4-M8	2.76			0.70	0.55	0.71		0.63	0.2x1.57	7.98
8	30:1	10.98	8.07	2.83	2.87	2.60	1.22	11.38	11.81	4-M8	2.76			0.81	0.67	0.87		0.75	0.25x1.97	14.77
10	30:1	10.98	8.07	2.83	2.99	2.60	1.34	11.50	11.81	4-M10	4.02			0.81	0.87	1.00		0.75	0.25x1.97	15.83
12	50:1	11.18	8.10	3.23	3.19	3.17	1.29	12.19	11.81	4-M10	4.02			0.95	0.87	1.10		0.75	0.25x1.97	21.12
14	50:1	11.18	8.10	3.07	3.46	3.09	1.36	12.46	11.81	4-M10	4.02	0.2	0.39	2.81	0.00	1.10	2.36	0.75	0.25x1.97	20.81
16	50:1	11.18	8.10	3.07	3.46	3.09	1.36	12.46	11.81	4-M16	5.51	0.2	0.39	3.15	0.00	1.26	2.36	0.75	0.25x1.97	22.80
18	50:1	11.18	8.10	3.19	3.46	3.09	1.36	14.13	15.16	4-M16	5.51	0.2	0.47	3.15	0.00	1.50	2.36	0.75	0.25x1.97	23.41
20	80:1	15.16	10.53	4.49	4.98	4.70	1.46	17.26	15.16	4-M20	6.50	0.2	0.47	3.54	0.00	1.77	2.76	0.98	0.33x2.01	51.90
24	80:1	15.16	10.53	4.49	4.98	4.70	1.46	17.26	15.16	4-M20	6.50	0.2	0.55	3.74	0.00	2.17	2.76	0.98	0.33x2.01	51.90



## Jflow Valve Material Selection & How To Order



# MEMO





# **JFLOW**<sup>®</sup> C O N T R O L S

